



## STEREO AUDIO DAC WITH USB INTERFACE, SINGLE-ENDED HEADPHONE OUTPUT AND S/PDIF OUTPUT

### FEATURES

- **On-Chip USB Interface:**
  - With Full-Speed Transceivers
  - Fully Compliant With USB 1.1 Specification
  - Certified by USB-IF
  - Partially Programmable Descriptors
  - Adaptive Isochronous Transfer for Playback
  - Bus-Powered or Self-Powered Operation
- **Sampling Rate: 32, 44.1, 48 kHz**
- **On-Chip Clock Generator:**  
Single 12-MHz Clock Source
- **Single Power Supply:**
  - Bus-Powered: 5 V, Typical ( $V_{BUS}$ )
  - Self-Powered: 3.3 V, Typical
- **16-Bit Delta-Sigma Stereo DAC**
  - Analog Performance at 5 V (Bus), 3.3 V (Self):
    - THD+N: 0.006% ( $R_L > 10\text{ k}\Omega$ , Self-Powered)
    - THD+N: 0.025% ( $R_L = 32\ \Omega$ )
    - SNR: 98 dB
    - Dynamic Range: 98 dB
    - $P_O$ : 12 mW ( $R_L = 32\ \Omega$ )
  - Oversampling Digital Filter
    - Pass-Band Ripple:  $\pm 0.04\text{ dB}$
    - Stop-Band Attenuation:  $-50\text{ dB}$
  - Single-Ended Voltage Output
  - Analog LPF Included
- **Multiple Functions:**
  - Up to Eight Human Interface Device (HID) Interfaces (Depending on Model and Settings)
  - Suspend Flag
  - S/PDIF Out With SCMS
  - External ROM Interface (PCM2704/6)
  - Serial Programming Interface (PCM2705/7)
  - I<sup>2</sup>S Interface (Selectable on PCM2706/7)
- **Package:**
  - Lead-Free Product
  - 28-Pin SSOP (PCM2704/5)
  - 32-Pin TQFP (PCM2706/7)

### APPLICATIONS

- USB Headphones
- USB Audio Speaker
- USB CRT/LCD Monitor
- USB Audio Interface Box
- USB-Featured Consumer Audio Product

### DESCRIPTION

The PCM2704/5/6/7 is TI's single-chip USB stereo audio DAC with USB 1.1 compliant full-speed protocol controller and S/PDIF. The USB-protocol controller works with no software code, but USB descriptors can be modified in some parts (for example, vendor ID/product ID) through the use of an external ROM (PCM2704/6) SPI (PCM2705/7) or on request.<sup>†</sup> The PCM2704/5/6/7 employs SpAct™ architecture, TI's unique system that recovers the audio clock from USB packet data. On-chip analog PLLs with SpAct enable playback with low clock jitter.



Please be aware that an important notice concerning availability, standard warranty, and use in critical applications of Texas Instruments semiconductor products and disclaimers thereto appears at the end of this data sheet.

<sup>†</sup>The modification of the USB descriptor through external ROM or SPI must comply with USB-IF guidelines, and the vendor ID must be your own ID as assigned by the USB-IF. The descriptor also can be modified by changing a mask; please contact your representative for details.

SpAct is a trademark of Texas Instruments.



This integrated circuit can be damaged by ESD. Texas Instruments recommends that all integrated circuits be handled with appropriate precautions. Failure to observe proper handling and installation procedures can cause damage.

ESD damage can range from subtle performance degradation to complete device failure. Precision integrated circuits may be more susceptible to damage because very small parametric changes could cause the device not to meet its published specifications.

## PACKAGE ORDERING INFORMATION(1)

PRODUCT	PACKAGE-LEAD	PACKAGE CODE	OPERATING TEMPERATURE RANGE	PACKAGE MARKING	ORDERING NUMBER	TRANSPORT MEDIA
PCM2704DB	SSOP-28	28DB	–25°C to 85°C	PCM2704	PCM2704DB	Tube
					PCM2704DBR	Tape and reel
PCM2705DB	SSOP-28	28DB	–25°C to 85°C	PCM2705	PCM2705DB	Tube
					PCM2705DBR	Tape and reel
PCM2706PJT	TQFP-32	32PJT	–25°C to 85°C	PCM2706	PCM2706PJT	Tray
					PCM2706PJTR	Tape and reel
PCM2707PJT	TQFP-32	32PJT	–25°C to 85°C	PCM2707	PCM2707PJT	Tray
					PCM2707PJTR	Tape and reel

(1) For the most current specification and package information, refer to our Web site at [www.ti.com](http://www.ti.com).

## ABSOLUTE MAXIMUM RATINGS

over operating free-air temperature range unless otherwise noted(1)

		UNITS
Supply voltage	V <sub>BUS</sub>	–0.3 V to 6.5 V
	V <sub>CCP</sub> , V <sub>CCL</sub> , V <sub>CCR</sub> , V <sub>DD</sub>	–0.3 V to 4 V
Supply voltage differences	V <sub>CCP</sub> , V <sub>CCL</sub> , V <sub>CCR</sub> , V <sub>DD</sub>	±0.1 V
Ground voltage differences	PGND, AGNDL, AGNDR, DGND, ZGND	±0.1 V
Digital input voltage	HOST	–0.3 V to 6.5 V
	D+, D–, HID0/MS, HID1/MC, HID2/MD, XT1, XTO, DOUT, <u>SSPND</u> , CK, DT, PSEL, FSEL, TEST, TEST0, TEST1, FUNC0, FUNC1, FUNC2, FUNC3	–0.3 V to (V <sub>DD</sub> + 0.3) V < 4 V
Analog input voltage	V <sub>COM</sub>	–0.3 V to (V <sub>CCP</sub> + 0.3) V < 4 V
	V <sub>OUTR</sub>	–0.3 V to (V <sub>CCR</sub> + 0.3) V < 4 V
	V <sub>OUTL</sub>	–0.3 V to (V <sub>CCL</sub> + 0.3) V < 4 V
Input current (any pins except supplies)		±10 mA
Ambient temperature under bias		–40°C to 125°C
Storage temperature		–55°C to 150°C
Junction temperature		150°C
Lead temperature (soldering)		260°C, 5 s
Package temperature (IR reflow, peak)		260°C

(1) Stresses beyond those listed under “absolute maximum ratings” may cause permanent damage to the device. These are stress ratings only, and functional operation of the device at these or any other conditions beyond those indicated under “recommended operating conditions” is not implied. Exposure to absolute-maximum-rated conditions for extended periods may affect device reliability.

## ELECTRICAL CHARACTERISTICS

all specifications at  $T_A = 25^\circ\text{C}$ ,  $V_{\text{BUS}} = 5\text{ V}$ ,  $f_S = 44.1\text{ kHz}$ ,  $f_{\text{IN}} = 1\text{ kHz}$ , 16-bit data, unless otherwise noted

PARAMETER		TEST CONDITIONS	PCM2704DB, PCM2705DB, PCM2706PJT, PCM2707PJT			UNIT
			MIN	TYP	MAX	
<b>DIGITAL INPUT/OUTPUT</b>						
Host interface			Apply USB revision 1.1, full-speed			
Audio data format			USB isochronous data format			
<b>INPUT LOGIC</b>						
$V_{\text{IH}}$	Input logic level		2		3.3	VDC
$V_{\text{IL}}$			-0.3		0.8	
$V_{\text{IH}}^{(1)}$			2		5.5	
$V_{\text{IL}}^{(1)}$			-0.3		0.8	
$I_{\text{IH}}^{(2)}$	Input logic current	$V_{\text{IN}} = 3.3\text{ V}$			$\pm 10$	$\mu\text{A}$
$I_{\text{IL}}^{(2)}$		$V_{\text{IN}} = 0\text{ V}$			$\pm 10$	
$I_{\text{IH}}$		$V_{\text{IN}} = 3.3\text{ V}$		65	100	
$I_{\text{IL}}$		$V_{\text{IN}} = 0\text{ V}$			$\pm 10$	
<b>OUTPUT LOGIC</b>						
$V_{\text{OH}}^{(3)}$	Output logic level	$I_{\text{OH}} = -2\text{ mA}$	2.8			VDC
$V_{\text{OL}}^{(3)}$		$I_{\text{OL}} = 2\text{ mA}$			0.3	
$V_{\text{OH}}$		$I_{\text{OH}} = -2\text{ mA}$	2.4			
$V_{\text{OL}}$		$I_{\text{OL}} = 2\text{ mA}$			0.4	
<b>CLOCK FREQUENCY</b>						
Input clock frequency, XT1			11.994	12	12.006	MHz
$f_S$	Sampling frequency		32, 44.1, 48			kHz
<b>DAC CHARACTERISTICS</b>						
Resolution			16			Bits
Audio data channel			1, 2			Channel
<b>DC ACCURACY</b>						
Gain mismatch, channel-to-channel			$\pm 2$	$\pm 8$		% of FSR
Gain error			$\pm 2$	$\pm 8$		% of FSR
Bipolar zero error			$\pm 3$	$\pm 6$		% of FSR
<b>DYNAMIC PERFORMANCE<sup>(4)</sup></b>						
THD+N, $V_{\text{OUT}} = 0\text{ dB}$	Line <sup>(5)</sup>	$R_L > 10\text{ k}\Omega$ , self-powered	0.006%	0.01%		
		$R_L > 10\text{ k}\Omega$ , bus-powered	0.012%	0.02%		
	Headphone	$R_L = 32\ \Omega$ , self-/bus-powered	0.025%			
THD+N, $V_{\text{OUT}} = -60\text{ dB}$			2%			
Dynamic range		EIAJ, A-weighted	90	98		dB
S/N ratio		EIAJ, A-weighted	90	98		dB
Channel separation			60	70		dB

(1) HOST

(2) D+, D-, HOST, TEST, TEST0, TEST1, DT, PSEL, FSEL, XT1

(3) FUNC0, FUNC1, FUNC2

(4)  $f_{\text{IN}} = 1\text{ kHz}$ , using the System Two™ Cascade audio measurement system by Audio Precision™ in the RMS mode with a 20-kHz LPF and 400-Hz HPF.

(5) THD+N performance varies slightly depending on the effective output load, including dummy load R7, R8 in Figure 31.

## ELECTRICAL CHARACTERISTICS (CONTINUED)

all specifications at  $T_A = 25^\circ\text{C}$ ,  $V_{BUS} = 5\text{ V}$ ,  $f_S = 44.1\text{ kHz}$ ,  $f_{IN} = 1\text{ kHz}$ , 16-bit data, unless otherwise noted

PARAMETER		TEST CONDITIONS	PCM2704DB, PCM2705DB, PCM2706PJT, PCM2707PJT			UNIT	
			MIN	TYP	MAX		
<b>ANALOG OUTPUT</b>							
Output voltage			0.55 $V_{CCL}$ , 0.55 $V_{CCR}$			Vp-p	
Center voltage			0.5 $V_{CCP}$			V	
Load impedance	Line	AC coupling	10			k $\Omega$	
	Headphone	AC coupling	16	32		$\Omega$	
LPF frequency response		-3 dB	140			kHz	
		f = 20 kHz	-0.1			dB	
<b>DIGITAL FILTER PERFORMANCE</b>							
Pass band			0.454 $f_S$			Hz	
Stop band			0.546 $f_S$			Hz	
Pass-band ripple			$\pm 0.04$			dB	
Stop-band attenuation			-50			dB	
Delay time			20/ $f_S$			s	
<b>POWER SUPPLY REQUIREMENTS</b>							
Voltage range	$V_{BUS}$	Bus-powered	4.35	5	5.25	VDC	
	$V_{CCP}$ , $V_{CCL}$ , $V_{CCR}$ , $V_{DD}$	Self-powered	3	3.3	3.6		
Supply current	Line	DAC operation	23			30	mA
	Headphone	DAC operation ( $R_L = 32\ \Omega$ )	35			46	
	Line/headphone	Suspend mode <sup>(1)</sup>	150			190	
Power dissipation (self-powered)	Line	DAC operation	76			108	mW
	Headphone	DAC operation ( $R_L = 32\ \Omega$ )	116			166	
	Line/headphone	Suspend mode <sup>(1)</sup>	495			684	
Power dissipation (bus-powered)	Line	DAC operation	115			158	mW
	Headphone	DAC operation ( $R_L = 32\ \Omega$ )	175			242	
	Line/headphone	Suspend mode <sup>(1)</sup>	750			998	
Internal power supply voltage (2)	$V_{CCP}$ , $V_{CCL}$ , $V_{CCR}$ , $V_{DD}$	Bus-powered	3.2	3.35	3.5	VDC	
<b>TEMPERATURE RANGE</b>							
Operating temperature			-25			85	$^\circ\text{C}$
$\theta_{JA}$	Thermal resistance	28-pin SSOP (PCM2704/5)				100	$^\circ\text{C/W}$
		32-pin TQFP (PCM2706/7)				80	

(1) Under USB suspend state.

(2)  $V_{DD}$ ,  $V_{CCP}$ ,  $V_{CCL}$ ,  $V_{CCR}$ . These pins work as output pins of internal power supply for bus-powered operation.

**PIN ASSIGNMENTS**

**PCM2704/PCM2705  
DB PACKAGE  
(TOP VIEW)**

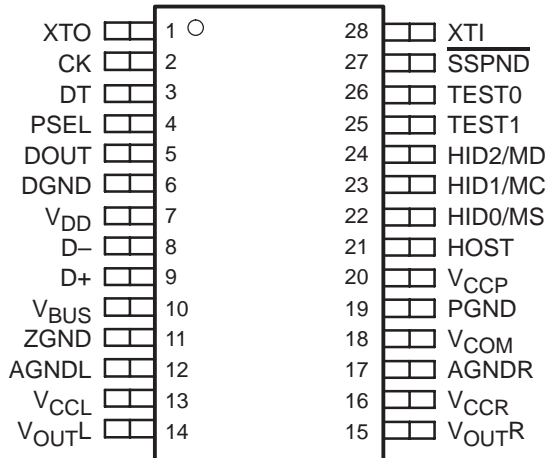

**PCM2706/PCM2707  
PJT PACKAGE  
(TOP VIEW)**

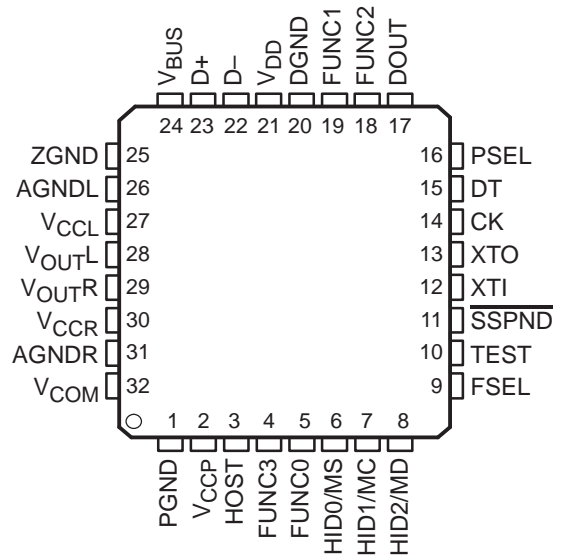

Terminal Functions (PCM2704DB/PCM2705DB)

TERMINAL NAME	NO.	I/O	DESCRIPTION
AGNDL	12	—	Analog ground for headphone amplifier of L-channel
AGNDR	17	—	Analog ground for headphone amplifier of R-channel
CK	2	O	Clock output for external ROM (PCM2704). Must be left open (PCM2705).
D+	9	I/O	USB differential input/output plus <sup>(1)</sup>
D-	8	I/O	USB differential input/output minus <sup>(1)</sup>
DGND	6	—	Digital ground
DOUT	5	O	S/PDIF output
DT	3	I/O	Data input/output for external ROM(PCM 2704). Must be left open with pullup resistor (PCM2705). <sup>(1)</sup>
HID0/MS	22	I	HID key state input (mute), active HIGH (PCM2704). MS input (PCM2705). <sup>(3)</sup>
HID1/MC	23	I	HID key state input (volume up), active HIGH (PCM2704). MC input (PCM2705). <sup>(3)</sup>
HID2/MD	24	I	HID key state input (volume down), active HIGH (PCM2704). MD input (PCM2705). <sup>(3)</sup>
HOST	21	I	Host detection during self-powered operation (connect to V <sub>BUS</sub> ). Max power select during bus-powered operation (LOW: 100 mA, HIGH: 500 mA). <sup>(2)</sup>
PGND	19	—	Analog ground for DAC, OSC and PLL
PSEL	4	I	Power source select. (LOW: self-power, HIGH: bus-power) <sup>(1)</sup>
SSPND	27	O	Suspend flag, active LOW (LOW: suspend, HIGH: operational)
TEST0	26	I	Test pin. Must be set HIGH <sup>(1)</sup>
TEST1	25	I	Test pin. Must be set HIGH <sup>(1)</sup>
V <sub>BUS</sub>	10	—	Connect to USB power (V <sub>BUS</sub> ) for bus-powered operation. Connect to V <sub>DD</sub> for self-powered operation.
V <sub>CCL</sub>	13	—	Analog power supply for headphone amplifier of L-channel <sup>(4)</sup>
V <sub>CCP</sub>	20	—	Analog power supply for DAC, OSC and PLL <sup>(4)</sup>
V <sub>CCR</sub>	16	—	Analog power supply for headphone amplifier of R-channel <sup>(4)</sup>
V <sub>COM</sub>	18	—	Common voltage for DAC (V <sub>CCP</sub> /2). Connect decoupling capacitor to PGND.
V <sub>DD</sub>	7	—	Digital power supply <sup>(4)</sup>
V <sub>OUTL</sub>	14	O	DAC analog output for L-channel
V <sub>OUTR</sub>	15	O	DAC analog output for R-channel
XTI	28	I	Crystal oscillator input <sup>(1)</sup>
XTO	1	O	Crystal oscillator output
ZGND	11	—	Ground for internal regulator

<sup>(1)</sup> LV-TTL level

<sup>(2)</sup> LV-TTL level, 5-V tolerant

<sup>(3)</sup> LV-TTL level with internal pulldown

<sup>(4)</sup> Connect decoupling capacitor to GND. Supply 3.3 V for self-powered applications.

---

**Terminal Functions (PCM2706PJT/PCM2707PJT)**

TERMINAL NAME NO.		I/O	DESCRIPTION
AGNDL	26	—	Analog ground for headphone amplifier of L-channel
AGNDR	31	—	Analog ground for headphone amplifier of R-channel
CK	14	O	Clock output for external ROM (PCM2706). Must be left open (PCM2707).
D+	23	I/O	

BLOCK DIAGRAM (PCM2704DB/PCM2705DB)

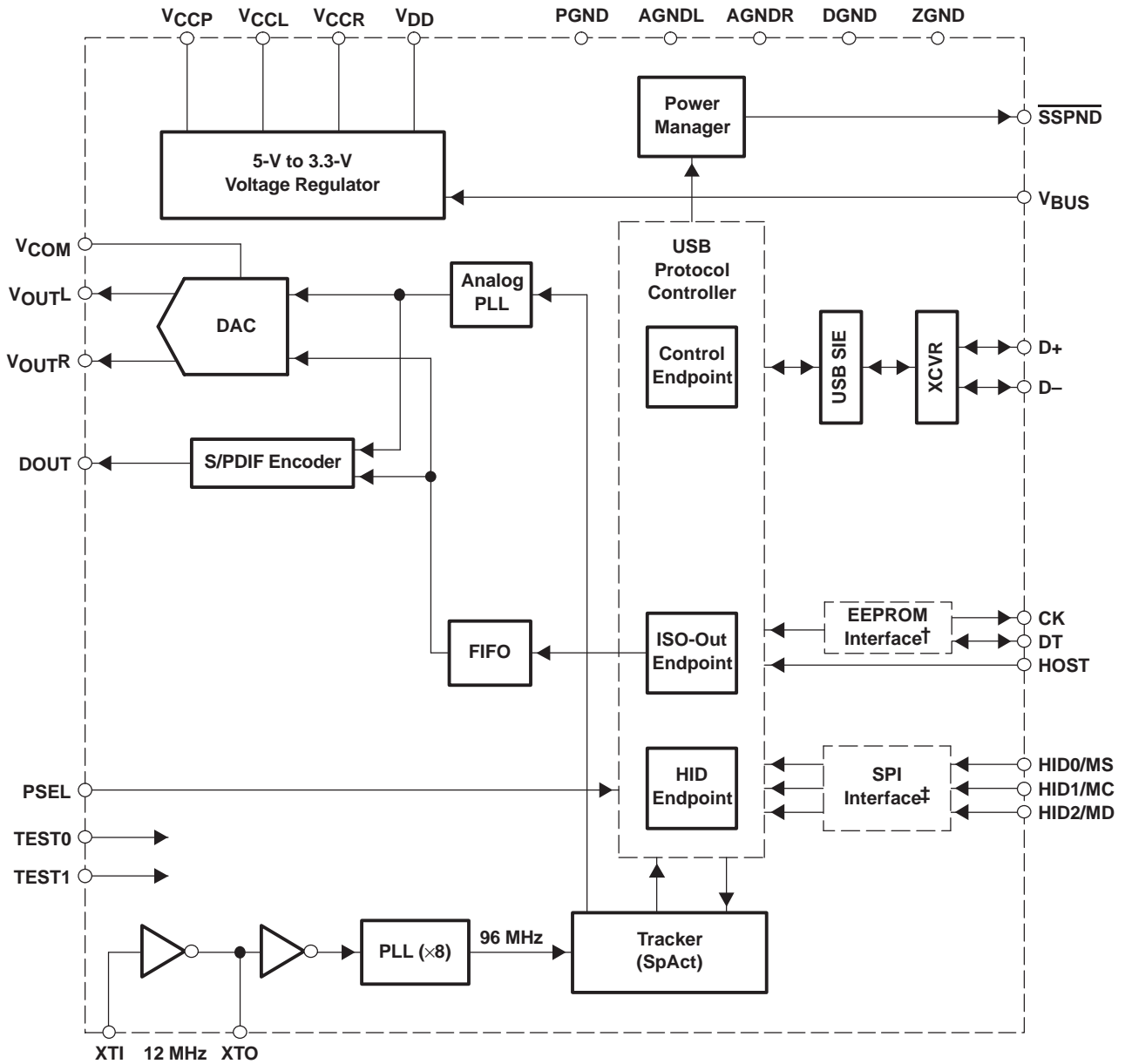

† Applies to PCM2704DB

‡ Applies to PCM2705DB



BLOCK DIAGRAM (PCM2706PJT/PCM2707PJT)

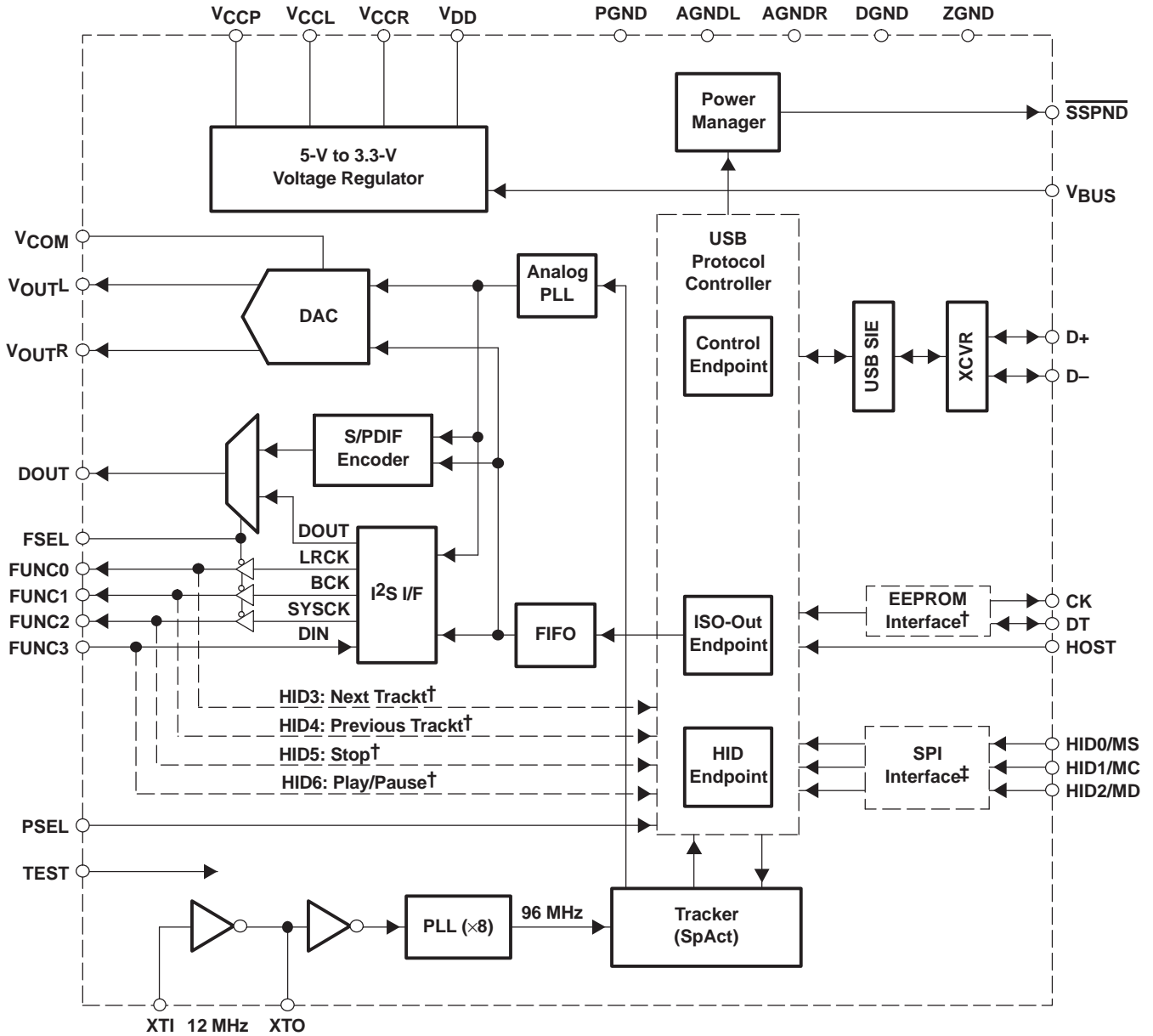

† Applies to PCM2706PJT

‡ Applies to PCM2707PJT

TYPICAL PERFORMANCE CURVES OF INTERNAL FILTER

DAC DIGITAL INTERPOLATION FILTER FREQUENCY RESPONSE

AMPLITUDE  
vs  
FREQUENCY

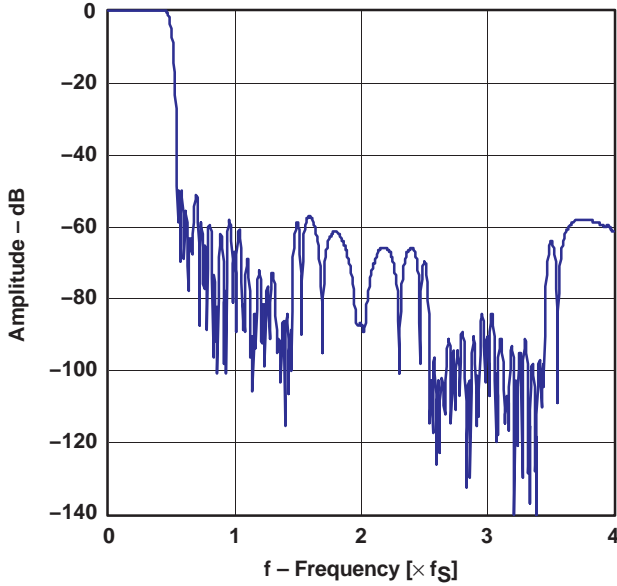

Figure 1. Frequency Response

AMPLITUDE  
vs  
FREQUENCY

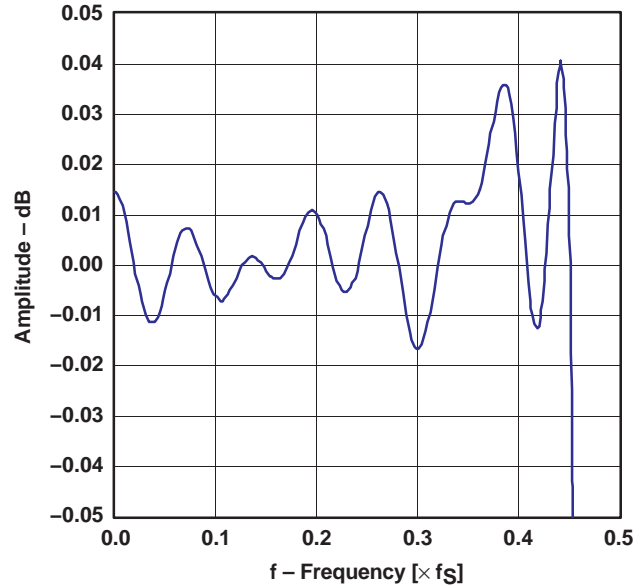

Figure 2. Pass-Band Ripple

DAC ANALOG LOW-PASS FILTER FREQUENCY RESPONSE

AMPLITUDE  
vs  
FREQUENCY

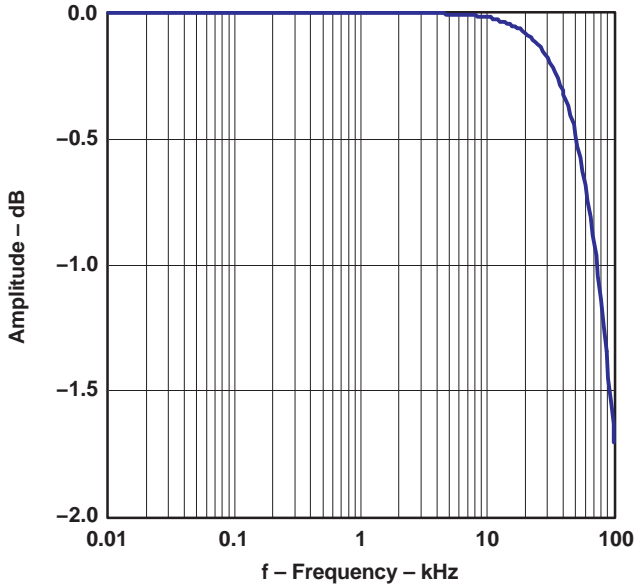

Figure 3. Pass-Band Characteristics

AMPLITUDE  
vs  
FREQUENCY

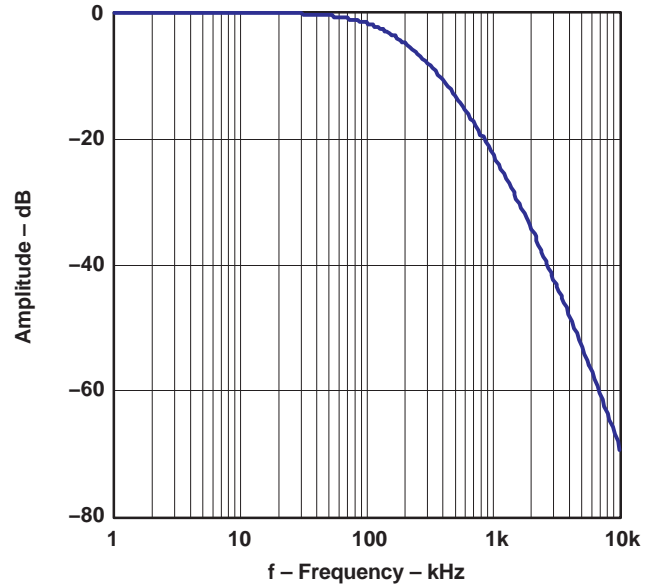

Figure 4. Stop-Band Characteristics

All specifications at  $T_A = 25^\circ\text{C}$ ,  $V_{BUS} = 5\text{ V}$ ,  $f_S = 44.1\text{ kHz}$ ,  $f_{IN} = 1\text{ kHz}$ , 16-bit data, unless otherwise noted.

TYPICAL PERFORMANCE CURVES

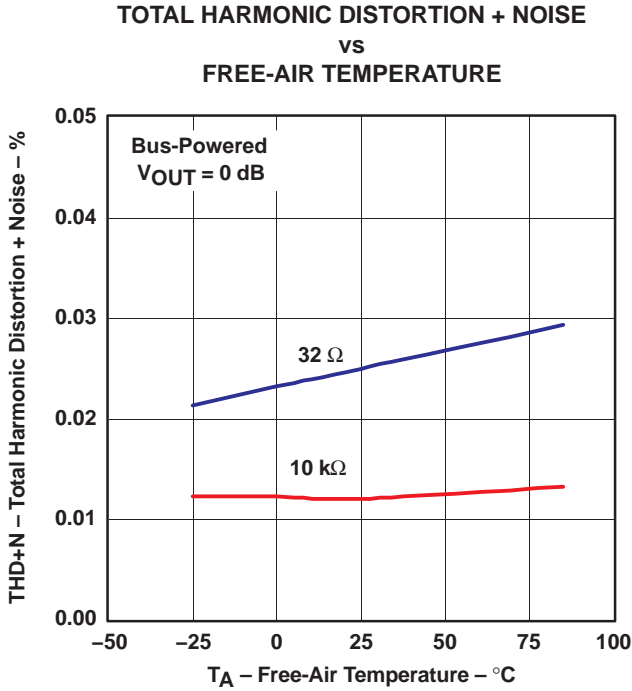

Figure 5

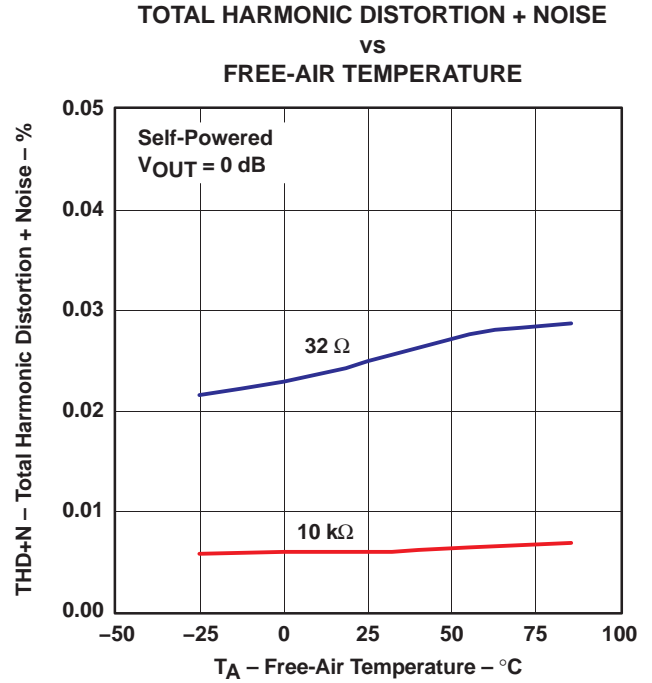

Figure 6

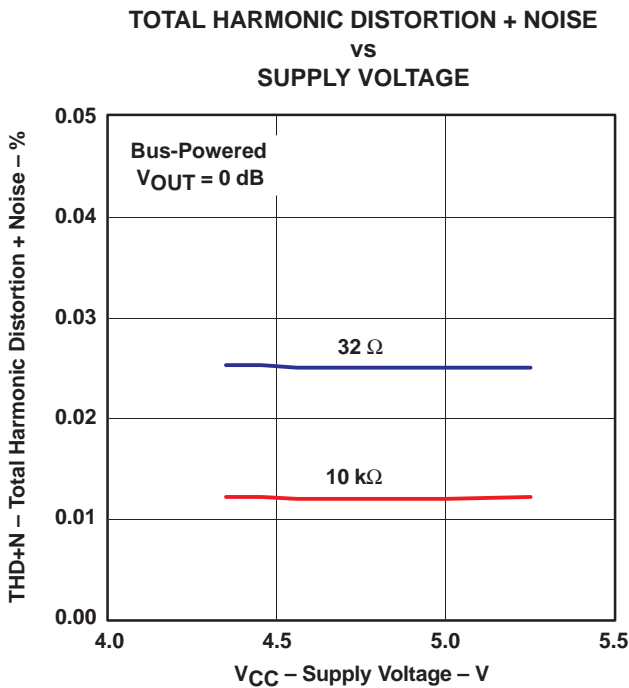

Figure 7

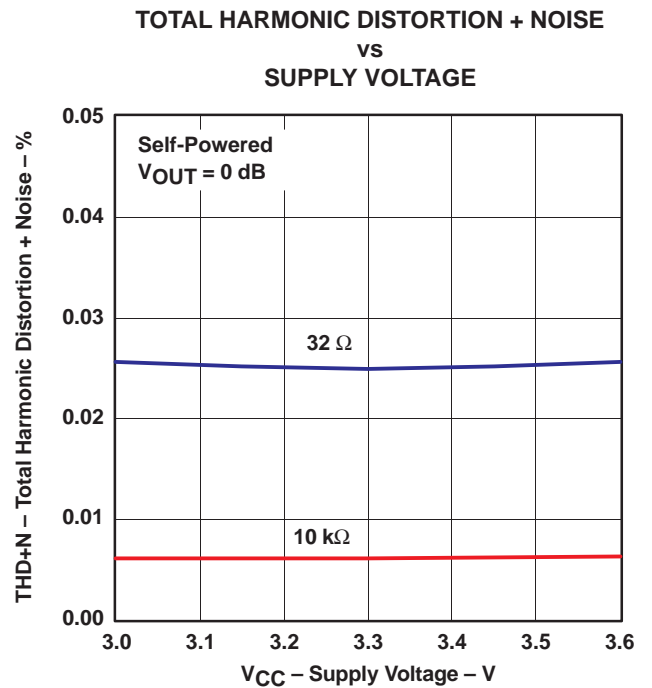

Figure 8

All specifications at  $T_A = 25^\circ\text{C}$ ,  $V_{BUS} = 5 \text{ V}$ ,  $f_S = 44.1 \text{ kHz}$ ,  $f_{IN} = 1 \text{ kHz}$ , 16-bit data, unless otherwise noted.

TOTAL HARMONIC DISTORTION + NOISE  
VS  
SAMPLING FREQUENCY

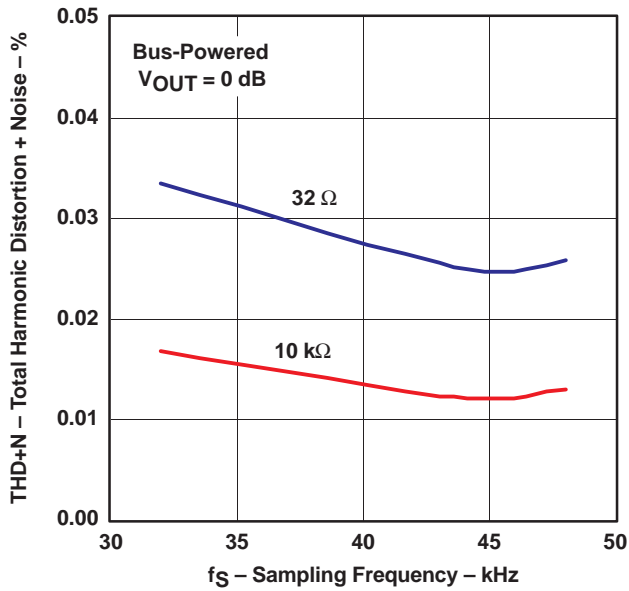

Figure 9

TOTAL HARMONIC DISTORTION + NOISE  
VS  
SAMPLING FREQUENCY

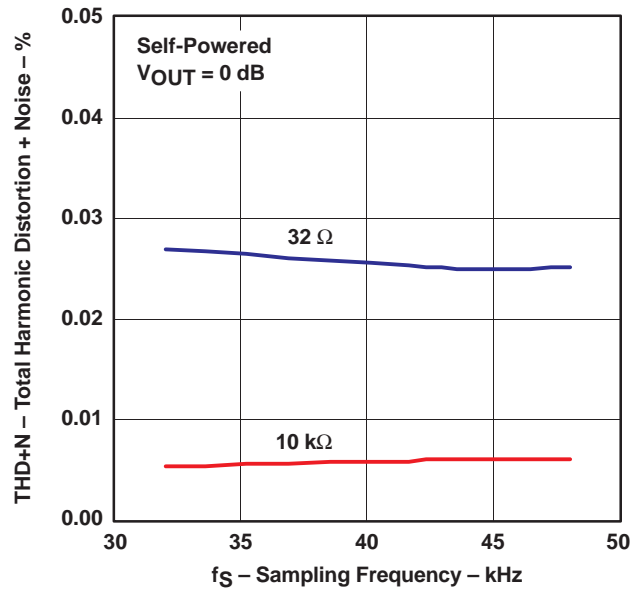

Figure 10

DYNAMIC RANGE and SNR  
VS  
FREE-AIR TEMPERATURE

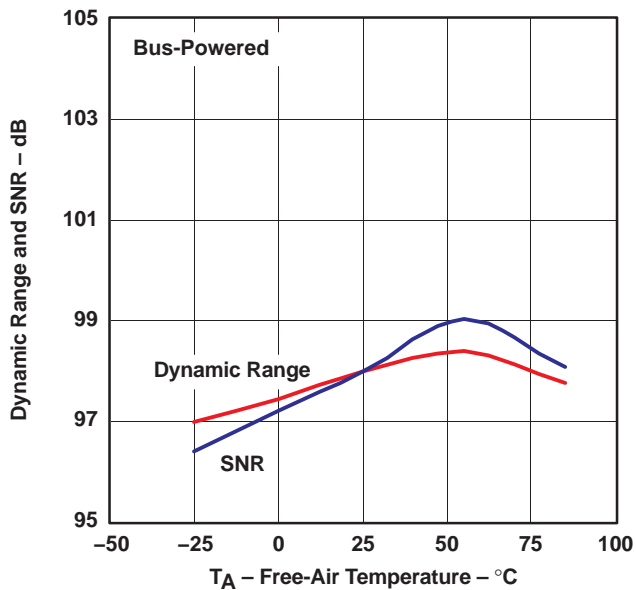

Figure 11

DYNAMIC RANGE and SNR  
VS  
FREE-AIR TEMPERATURE

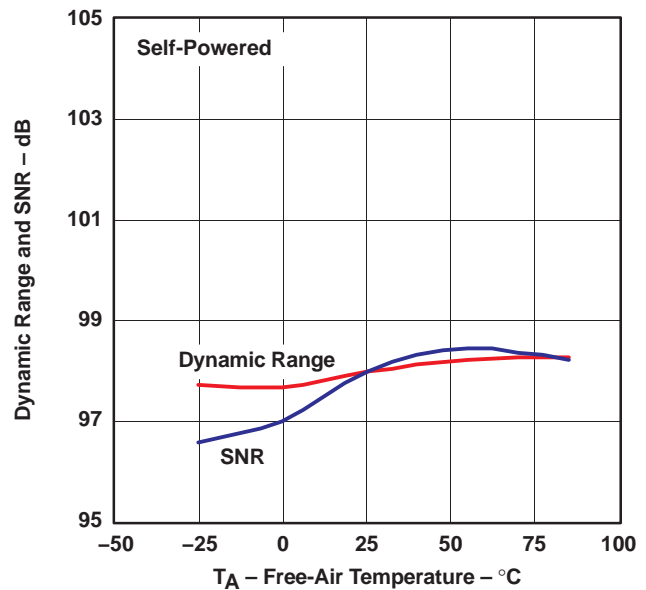
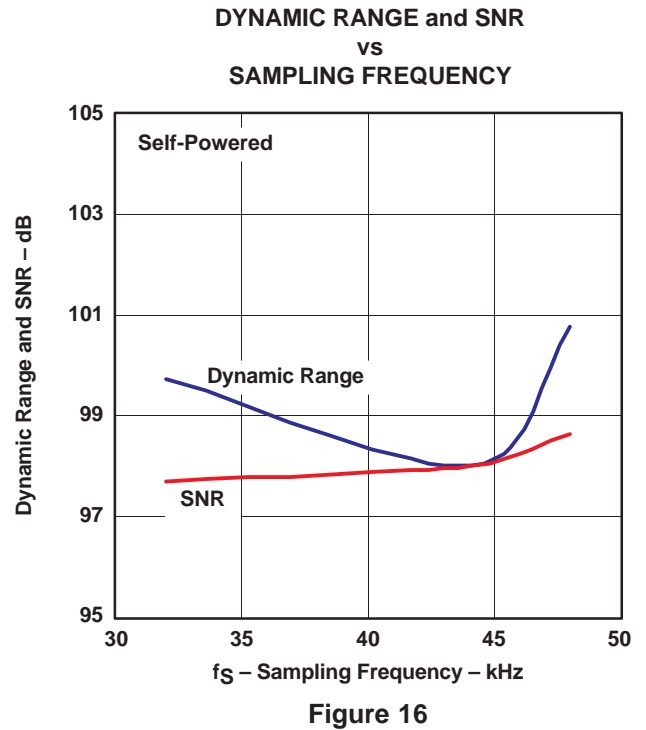
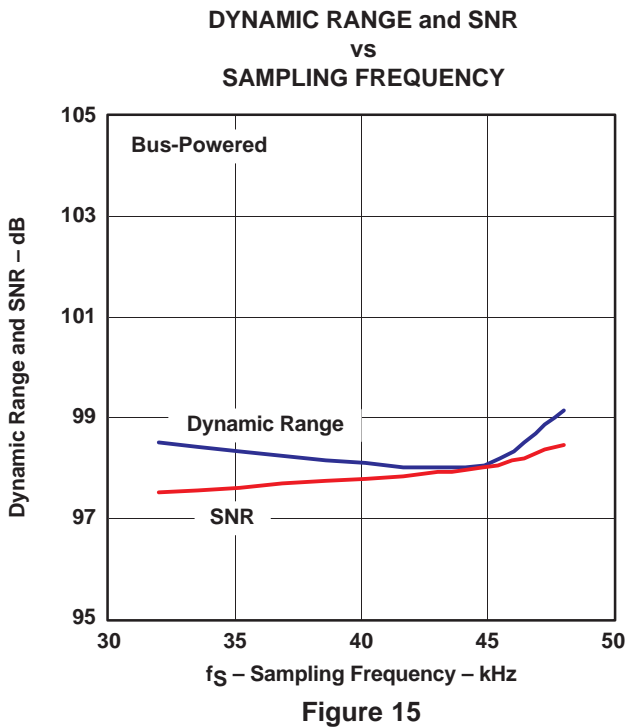
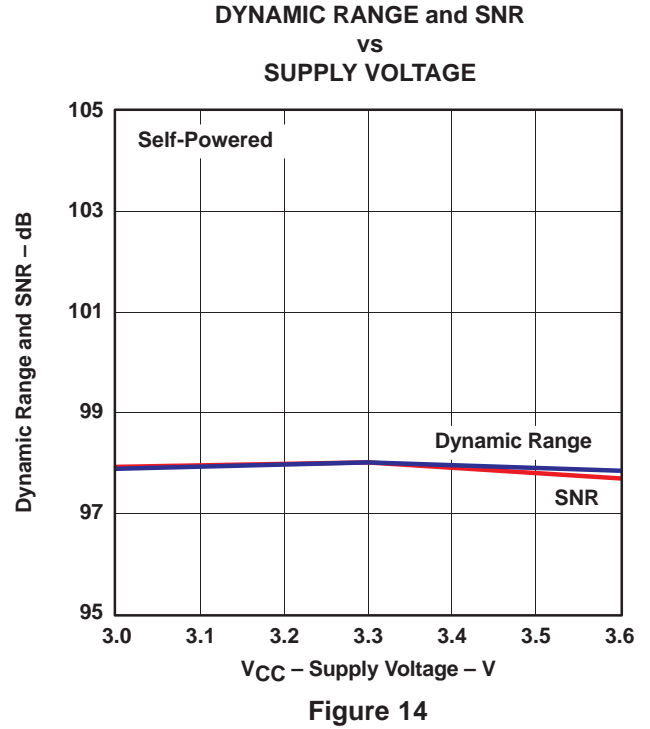
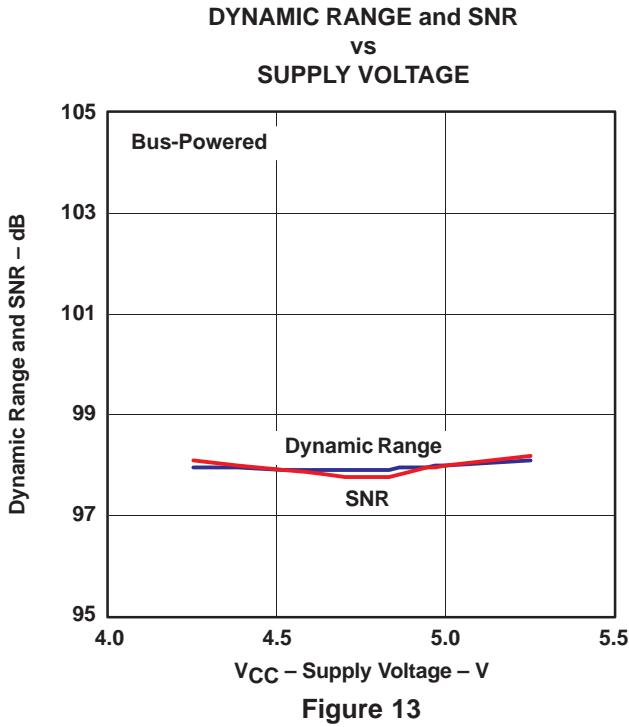

Figure 12

All specifications at T<sub>A</sub> = 25°C, V<sub>BUS</sub> = 5 V, f<sub>S</sub> = 44.1 kHz, f<sub>IN</sub> = 1 kHz, 16-bit data, unless otherwise noted.



SUSPEND CURRENT  
vs  
SUPPLY VOLTAGE

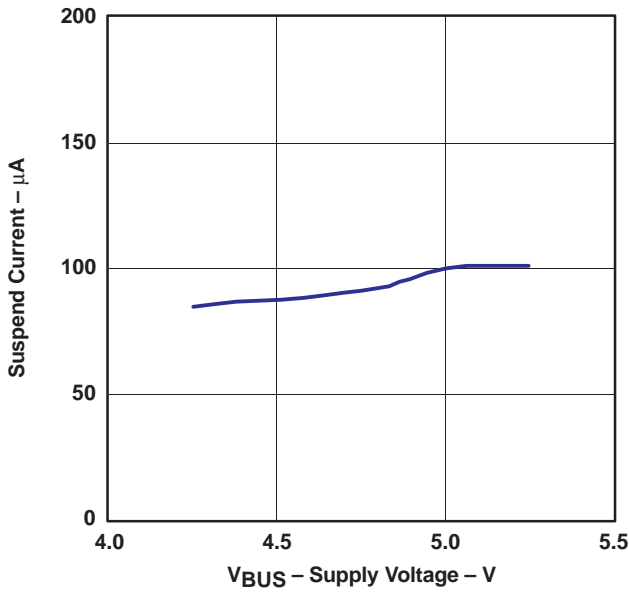

Figure 17

SUSPEND CURRENT  
vs  
FREE-AIR TEMPERATURE

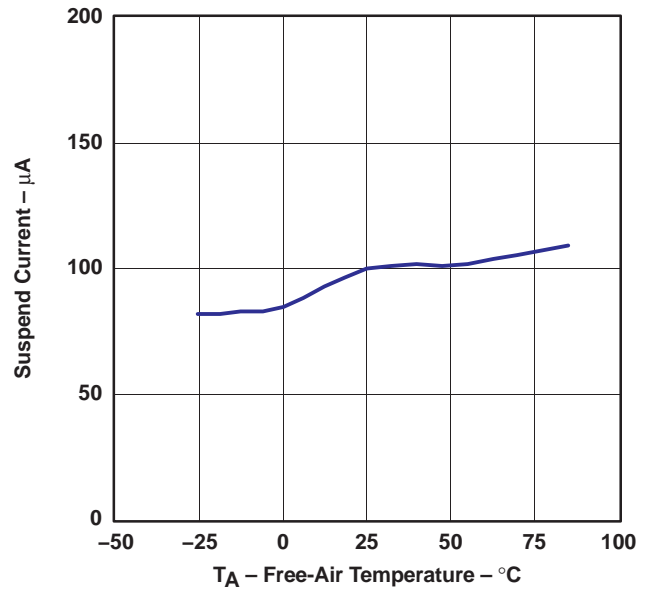

Figure 18

AMPLITUDE  
vs  
FREQUENCY

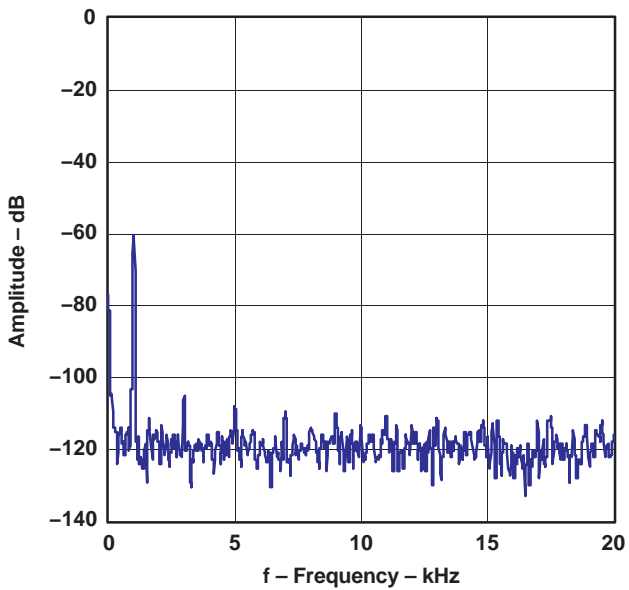

Figure 19. Output Spectrum (-60 dB, N = 8192)

AMPLITUDE  
vs  
FREQUENCY

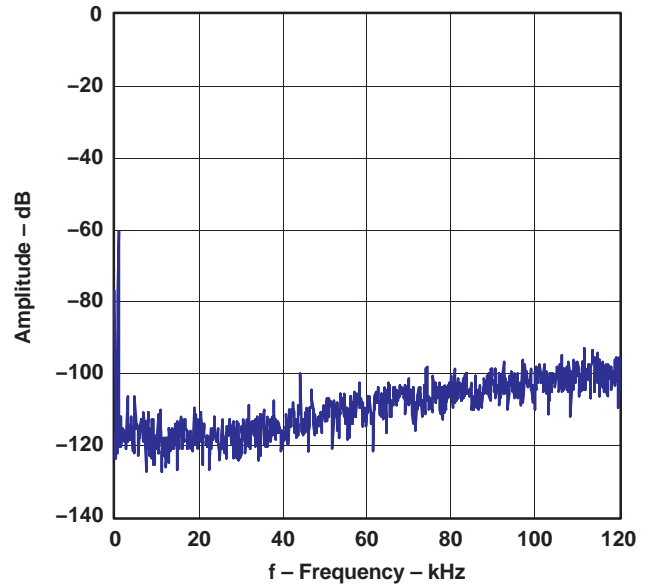

Figure 20. Output Spectrum (-60 dB, N = 8192)

## DETAILED DESCRIPTION

### CLOCK AND RESET

For both USB function and audio function, the PCM2704/5/6/7 requires a 12-MHz ( $\pm 500$  ppm) clock, which can be generated by the built-in oscillator using a 12-MHz crystal resonator. The 12-MHz crystal resonator must be connected to XTI (pin 28 for PCM2704/5, pin 12 for PCM2706/7) and XTO (pin 1 for PCM2704/5, pin 13 for PCM2706/7) with one large (1-M $\Omega$ ) resistor and two small capacitors, the capacitance of which depends on the specified load capacitance of the crystal resonator. An external clock can be supplied from XTI (pin 28 for PCM2704/5, pin 12 for PCM2706/7). If an external clock is supplied, XTO (pin 1 for PCM2704/5, pin 13 for PCM2706/7) must be left open. Because no clock disabling pin is provided, it is not recommended to use the external clock supply. SSPND (pin 27 for PCM2704/5, pin 11 for PCM2706/7) is unable to use clock disabling.

The PCM2704/5/6/7 has an internal power-on reset circuit, and it works automatically when  $V_{DD}$  (pin 7 for PCM2704/5, pin 21 for PCM2706/7) exceeds 2 V typical (1.6 V–2.4 V), which is equivalent to  $V_{BUS}$  (pin 10 for PCM2704/5, pin 24 for PCM2706/7) exceeding 3 V typical for bus-powered applications. About 700  $\mu$ s is required until internal reset release.

### OPERATION MODE SELECTION

The PCM2704/5/6/7 has the following mode-select pins.

#### Power Configuration Select/Host Detection

PSEL (pin 4 for PCM2704/5, pin 16 for PCM2706/7) is dedicated to selecting the power source. This selection affects the configuration descriptor. While in bus-powered operation, maximum power consumption from the  $V_{BUS}$  is determined by HOST (pin 21 for PCM2704/5, pin 3 for PCM2706/7). For self-powered operation, HOST must be connected to  $V_{BUS}$  of the USB bus with a pulldown resistor to detect attach and detach. (To avoid excessive suspend current, the pulldown should be a high-value resistor.)

**Table 1. Power Configuration Select**

PSEL	DESCRIPTION
0	Self-powered
1	Bus-powered
HOST	DESCRIPTION
0	Detached from USB (self-powered)/100 mA (bus-powered)
1	Attached to USB (self-powered)/500 mA (bus-powered)

#### Function Select (PCM2706/7)

FSEL (pin 9) determines the function of FUNC0–FUNC3 (pins 4, 5, 18, and 19) and DOUT (pin17). When the I<sup>2</sup>S interface is required, FSEL must be set to LOW. Otherwise, FSEL must be set to HIGH.

**Table 2. Function Select**

FSEL	DOUT	FUNC0	FUNC1	FUNC2	FUNC3
0	Data out (I <sup>2</sup> S)	LRCK (I <sup>2</sup> S)	BCK (I <sup>2</sup> S)	SYSCK (I <sup>2</sup> S)	Data in (I <sup>2</sup> S)
1	S/PDIF data	Next track (HID) (1)	Previous track (HID) (1)	Stop (HID) (1)	Play/pause (HID) (1)

(1) Valid on the PCM2706; no function assigned on the PCM2707.

## USB INTERFACE

Control data and audio data are transferred to the PCM2704/5/6/7 via D+ (pin 9 for PCM2704/5, pin 23 for PCM2706/7) and D– (pin 8 for PCM2704/5, pin 22 for PCM2706/7). D+ should be pulled up with a 1.5-k $\Omega$  ( $\pm 5\%$ ) resistor. To avoid back voltage in self-powered operation, the device must not provide power to the pullup resistor on D+ while V<sub>BUS</sub> of the USB port is inactive.

All data to/from the PCM2704/5/6/7 are transferred at full speed. The following information is provided in the device descriptor. Some parts of the device descriptor can be modified through external ROM (PCM2704/6), SPI (PCM2705/7), or internal mask ROM on request.

**Table 3. Device Descriptor**

USB revision	1.1 compliant
Device class	0x00 (device defined interface level)
Device subclass	0x00 (not specified)
Device protocol	0x00 (not specified)
Max packet size for endpoint 0	8 bytes
Vendor ID	0x08BB (default value, can be modified)
Product ID	0x2704/0x2705/0x2706/0x2707 (These values correspond to the model number, and the value can be modified.)
Device release number	1.0 (0x0100)
Number of configurations	1
Vendor strings	“Burr-Brown from TI” (default value, can be modified)
Product strings	“USB Audio DAC” (default value, can be modified)
Serial number	Not supported

The following information is contained in the configuration descriptor. Some parts of the configuration descriptor can be modified through external ROM (PCM2704/6), SPI (PCM2705/7), or on request.

**Table 4. Configuration Descriptor**

Interface	Three interfaces
Power attribute	0x80 or 0xC0 (bus-powered or self-powered, depending on PSEL; no remote wake up. This value can be modified.)
Max power	0x0A, 0x32 or 0xFA (20 mA for self-powered, 100 mA or 500 mA for bus-powered, depending on PSEL and HOST. This value can be modified.)

The following information is contained in the string descriptor. Some parts of the string descriptor can be modified through external ROM (PCM2704/6), SPI (PCM2705/7), or on request.

**Table 5. String Descriptor**

#0	0x0409
#1	Burr-Brown from TI (default value, can be modified)
#2	USB Audio DAC (default value, can be modified)



## Device Configuration

Figure 21 illustrates the USB audio function topology. The PCM2704/5/6/7 has three interfaces. Each interface is enabled by some alternative settings.

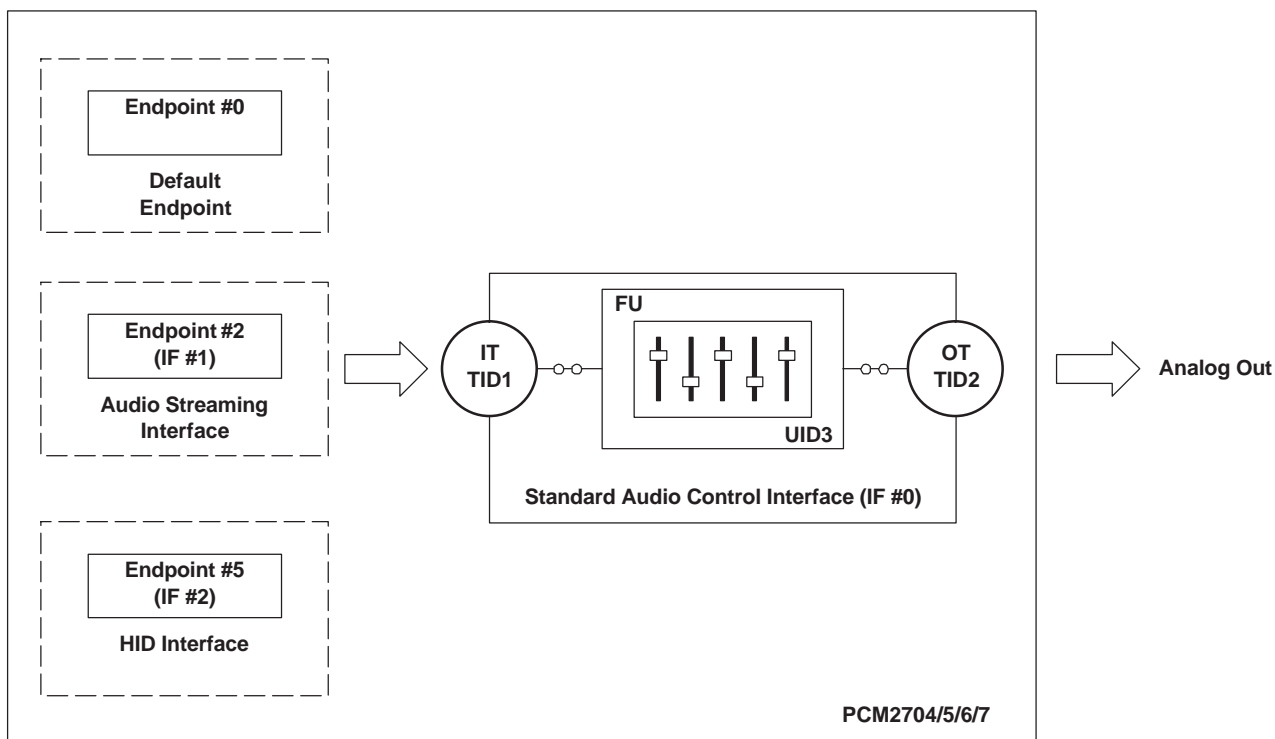

**Figure 21. USB Audio Function Topology**

### Interface #0 (Default/Control Interface)

Interface #0 is the control interface. Setting #0 is the only possible setting for interface #0. Setting #0 describes the standard audio control interface. Audio control interface consists of a terminal. The PCM2704/5/6/7 has three terminals as follows.

- Input terminal (IT #1) for isochronous-out stream
- Output terminal (OT #2) for audio analog output
- Feature unit (FU #3) for DAC digital attenuator

Input terminal #1 is defined as a USB stream (terminal type 0x0101). Input terminal #1 can accept two-channel audio streams constructed of left and right channels. Output terminal #2 is defined as a speaker (terminal type 0x0301). Feature unit #3 supports the following sound control features.

- Volume control
- Mute control

The built-in digital volume controller can be manipulated by an audio-class-specific request from 0 dB to –64 dB in steps of 1 dB. Changes are made by incrementing or decrementing one step (1 dB) for every  $1/f_S$  time interval until the volume level reaches the requested value. Each channel can be set to a separate value. The master volume control is not supported. A request to the master volume is stalled and ignored. The built-in digital mute controller can be manipulated by an audio-class-specific request. A master mute control request is acceptable. A mute control request to an individual channel is stalled and ignored. The digital volume control does not affect the S/PDIF and I<sup>2</sup>S outputs (PCM2706/7).

### Interface #1 (Isochronous-Out Interface)

Interface #1 is for the audio-streaming data-out interface. Interface #1 has the following three alternative settings. Alternative setting #0 is the zero-bandwidth setting. All other alternative settings are operational settings.

ALTERNATIVE SETTING	DATA FORMAT			TRANSFER MODE	SAMPLING RATE (kHz)
00	Zero bandwidth				
01	16-bit	stereo	2s complement (PCM)	Adaptive	32, 44.1, 48
02	16-bit	mono	2s complement (PCM)	Adaptive	32, 44.1, 48

### Interface #2 (HID Interface)

Interface #2 is the interrupt-data-in interface. Interface #2 comprises the HID consumer control device. Alternative setting #0 is the only possible setting for interface #2.

On the HID device descriptor, eight HID items are reported as follows for any model, in any configuration.

#### Basic HID operation

Interface #2 can report the following three key statuses for any model. These statuses can be set by the HID0–HID2 pins (PCM2704/6) or the SPI port (PCM2705/7).

- Mute (0xE2)
- Volume up (0xE9)
- Volume down (0xEA)

#### Extended HID operation (PCM2705/6/7)

By using the FUNC0–FUNC3 pins (PCM2706) or the SPI port (PCM2705/7), the following additional conditions can be reported to the host.

- Play/Pause (0xCD)
- Stop (0xB7)
- Previous (0xB6)
- Next (0xB5)

#### Auxiliary HID status report (PCM2705/7)

One additional HID status can be reported to the host though the SPI port. This status flag is defined by SPI command or external ROM. This definition must be described as on the report descriptor with a three-byte usage ID. *AL A/V Capture* (0x0193) is assigned as the default for this status flag.

#### Endpoints

The PCM2704/5/6/7 has three endpoints as follows.

- Control endpoint (EP #0)
- Isochronous-out audio data-stream endpoint (EP #2)
- HID endpoint (EP #5)

The control endpoint is a default endpoint. The control endpoint is used to control all functions of the PCM2704/5/6/7 by standard USB request and USB audio-class-specific request from the host. The isochronous-out audio data stream endpoint is an audio sink endpoint, which receives the PCM audio data. The isochronous-out audio data stream endpoint accepts the adaptive transfer mode. The HID endpoint is an interrupt-in endpoint. The HID endpoint reports HID status every 10 ms.

The HID endpoint is defined as a consumer control device. The HID function is designed as an independent endpoint from the isochronous-out endpoint. This means that the effect of HID operation depends on host software. Typically, the HID function is used to control the primary audio-out device.

## DAC

The PCM2704/5/6/7 has a DAC that uses an oversampling technique with  $128\text{-}f_s$  second-order multibit noise shaping. This technique provides extremely low quantization noise in the audio band, and the built-in analog low-pass filter removes the high-frequency components of the noise-shaping signal. DAC outputs are provided through the headphone amplifier  $V_{OUTL}$  and  $V_{OUTR}$  can provide 12 mW at  $32\ \Omega$  as well as 1.8 Vp-p into a 10-k $\Omega$  load.

## DIGITAL AUDIO INTERFACE – S/PDIF OUTPUT

The PCM2704/5/6/7 employs S/PDIF output. Isochronous-out data from the host is encoded to S/PDIF output DOUT as well as to DAC analog outputs  $V_{OUTL}$  and  $V_{OUTR}$ . Interface format and timing follows the IEC-60958 standard. Monaural data is converted to the stereo format at the same data rate. S/PDIF output is not supported in the I<sup>2</sup>S I/F enable mode.

### Channel Status Information

The channel status information is fixed as consumer application, PCM mode, copyright, digital/digital converter. All other bits are fixed as 0s except for the sample frequency, which is set automatically according to the data received through the USB.

### Copyright Management

Digital audio data output is always encoded as original with SCMS control. Only one generation of digital duplication is allowed. The implementation of this feature is optional. Note that it is your responsibility for determining whether to implement this feature in your product or not.

## DIGITAL AUDIO INTERFACE – I<sup>2</sup>S INTERFACE OUTPUT (PCM2706/7)

The PCM2706 and PCM2707 can support the I<sup>2</sup>S interface, which is enabled by FSEL (pin 9). In the I<sup>2</sup>S interface enabled mode, pins 4, 18, 19, 5, and 17 are assigned as DIN, SYSCK, BCK, LRCK, and DOUT, respectively. They provide digital output/input data in the 16-bit I<sup>2</sup>S format, which is also accepted by the internal DAC. I<sup>2</sup>S interface format and timing are shown in Figure 22 and Figure 23.

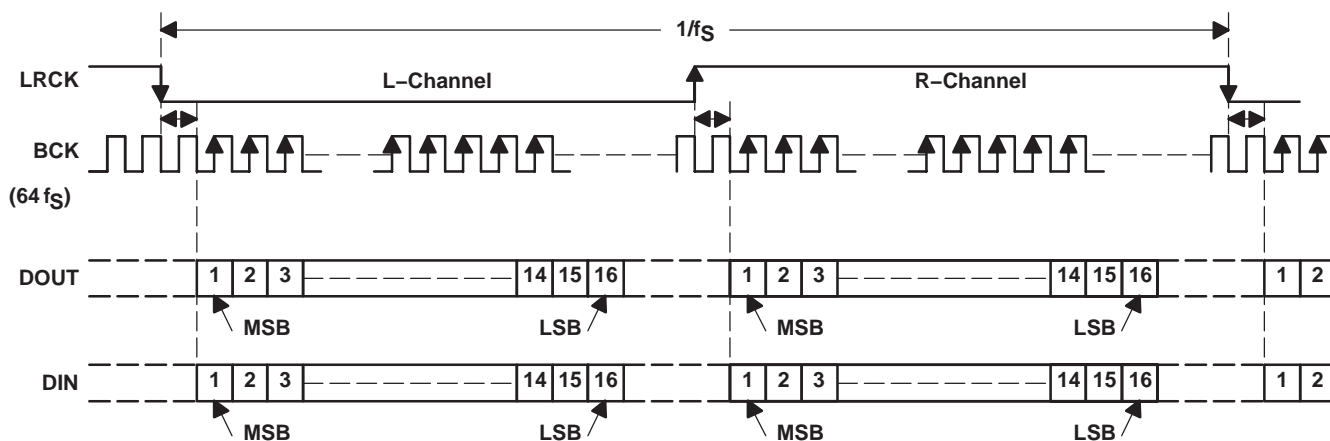
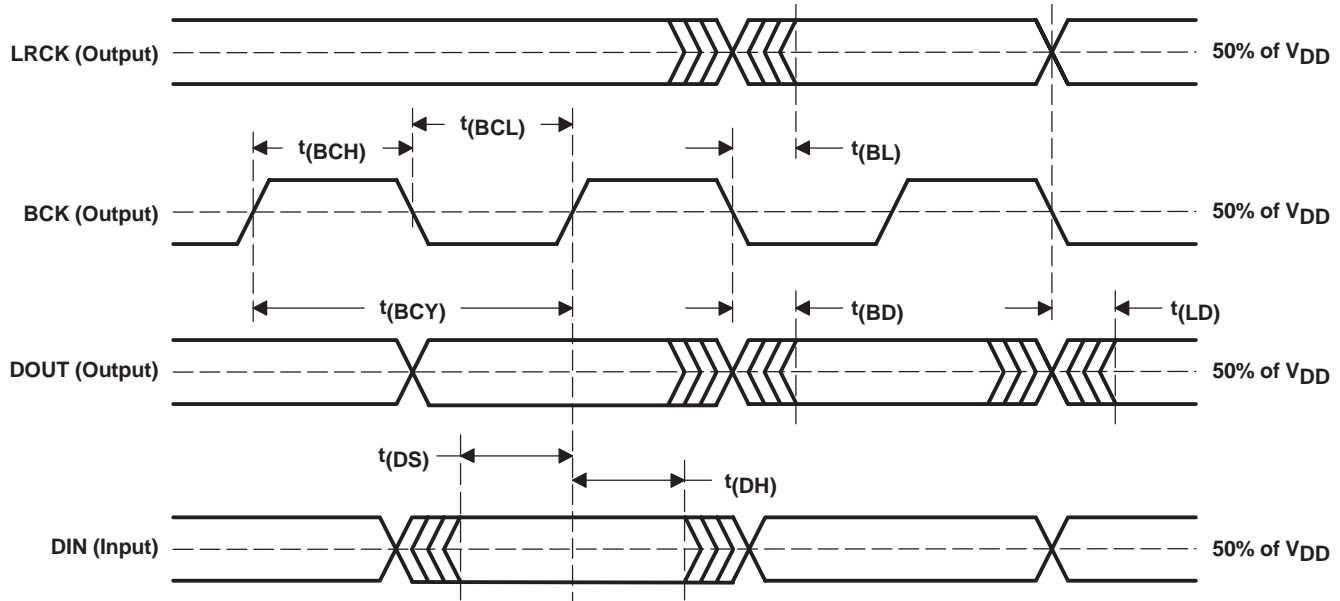

Figure 22. Audio Data Input Format



SYMBOL	PARAMETER	MIN	MAX	UNIT
t(BCY)	BCK pulse cycle time	300		ns
t(BCH)	BCK pulse duration, HIGH	100		ns
t(BCL)	BCK pulse duration, LOW	100		ns
t(BL)	LRCK delay time from BCK falling edge	-20	40	ns
t(BD)	DOUT delay time from BCK falling edge	-20	40	ns
t(LD)	DOUT delay time from LRCK edge	-20	40	ns
t(DS)	DIN setup time	20		ns
t(DH)	DIN hold time	20		ns

NOTE: Load capacitance is 20 pF.

Figure 23. Audio Interface Timing

## EXTERNAL ROM DESCRIPTOR (PCM2704/6)

The PCM2704/6 supports an external ROM interface to override internal descriptors. Pin 3 (for PCM2704)/pin 15 (for PCM2706) is assigned as DT (serial data) and pin 2 (for PCM2704)/pin 14 (for PCM2706) is assigned as CK (serial clock) of the I<sup>2</sup>C interface when using the external ROM descriptor. Descriptor data is transferred from the external ROM to the PCM2704/6 through the I<sup>2</sup>C interface the first time when the device activates after power-on reset. Before completing a read of the external ROM, the PCM2704/6 replies with NACK for any USB command request from the host to the device itself. The descriptor data, which can be in external ROM, are as follows. String descriptors must be described in ANSI ASCII code (1 byte for each character). String descriptors are automatically converted to unicode strings for transmission to the host. The device address of the external ROM is fixed as 0xA0. The data must be stored from address 0x00 and must consist of 57 bytes as described in the following items. Read operation is performed at a cycle of XTI/384 (approximately 30 kHz).

- Vendor ID (2 bytes)
- Product ID (2 bytes)
- Device string (16 bytes in ANSI ASCII code)
- Vendor string (32 bytes in ANSI ASCII code)
- Maximum power (1 byte)
- Power attribute (1 byte)
- Auxiliary HID usage ID in report descriptor (3 bytes)



**TIMING DIAGRAM**

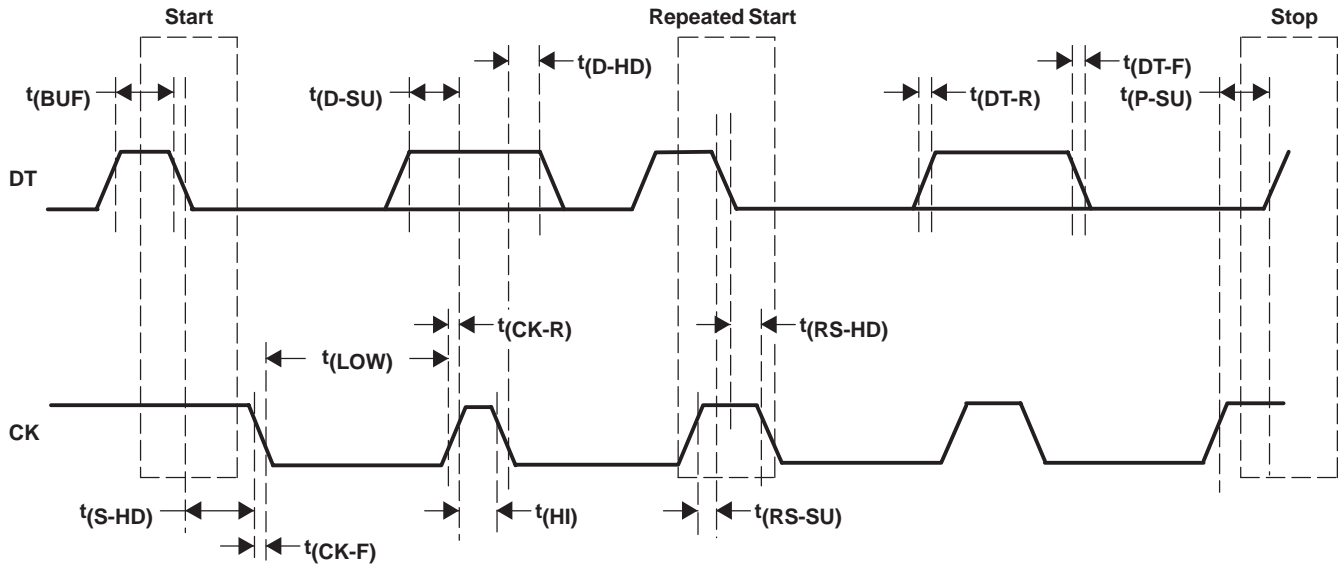

SYMBOL	PARAMETER	MIN	MAX	UNIT
$f_{CK}$	CK clock frequency		100	kHz
$t_{(BUF)}$	Bus free time between STOP and START condition	4.7		$\mu$ s
$t_{(LOW)}$	Low period of the CK clock	4.7		$\mu$ s
$t_{(HI)}$	High period of the CK clock	4		$\mu$ s
$t_{(RS-SU)}$	Setup time for START/repeated START condition	4.7		$\mu$ s
$t_{(S-HD)}$ $t_{(RS-HD)}$	Hold time for START/repeated START condition	4		$\mu$ s
$t_{(D-SU)}$	Data setup time	250		ns
$t_{(D-HD)}$	Data hold time	0	900	ns
$t_{(CK-R)}$	Rise time of CK signal	$20 + 0.1C_B$	1000	ns
$t_{(CK-F)}$	Fall time of CK signal	$20 + 0.1C_B$	1000	ns
$t_{(DT-R)}$	Rise time of DT signal	$20 + 0.1C_B$	1000	ns
$t_{(DT-F)}$	Fall time of DT signal	$20 + 0.1C_B$	1000	ns
$t_{(P-SU)}$	Setup time for STOP condition	4		$\mu$ s
$C_B$	Capacitive load for DT and CK line		400	pF
$V_{NH}$	Noise margin at HIGH level for each connected device (including hysteresis)	$0.2 V_{DD}$		V

**Figure 25. External ROM Read Interface Timing Requirements**

## EXTERNAL ROM EXAMPLE

Here is an example of external ROM data, with an explanation of the example following the data.

```

0xBB, 0x08, 0x04, 0x27,
0x50, 0x72, 0x6F, 0x64, 0x75, 0x63, 0x74, 0x20, 0x73, 0x74, 0x72, 0x69, 0x6E, 0x67, 0x73, 0x2E,
0x56, 0x65, 0x6E, 0x64, 0x6F, 0x72, 0x20, 0x73, 0x74, 0x72, 0x69, 0x6E, 0x67, 0x73, 0x20, 0x61,
0x72, 0x65, 0x20, 0x70, 0x6C, 0x61, 0x63, 0x65, 0x64, 0x20, 0x68, 0x65, 0x72, 0x65, 0x2E, 0x20,
0x80,
0x7D,
0x0A, 0x93, 0x01
  
```

The data is stored beginning at address 0x00.

Vendor ID: 0x08BB

Device ID: 0x2704

Device string: Product strings. (16 bytes)

Vendor string: Vendor strings are placed here. (32 bytes, 31 visible characters are followed by 1 space)

bmAttribute: 0x80 (Bus-powered)

maxPower: 0x7D (250 mA)

Auxiliary HID usage ID: 0x0A, 0x93, 0x01 (AL A/V capture)

## SERIAL PROGRAMMING INTERFACE (PCM2705/7)

The PCM2705/7 supports the serial programming interface (SPI) to program the descriptor and to set the HID state. Descriptor data is described in the *External ROM Descriptor* section.

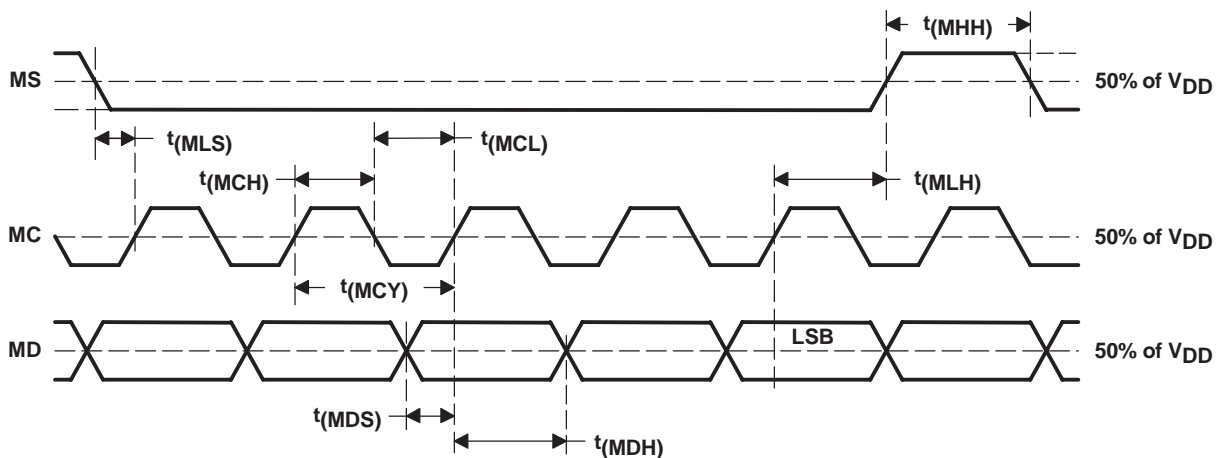

SYMBOL	PARAMETERS	MIN	TYP	MAX	UNITS
t(MCY)	MC pulse cycle time	100			ns
t(MCL)	MC low-level time	50			ns
t(MCH)	MC high-level time	50			ns
t(MHH)	MS high-level time	100			ns
t(MLS)	MS falling edge to MC rising edge	20			ns
t(MLH)	MS hold time	20			ns
t(MDH)	MD hold time	15			ns
t(MDS)	MD setup time	20			ns

Figure 26. SPI Timing Diagram

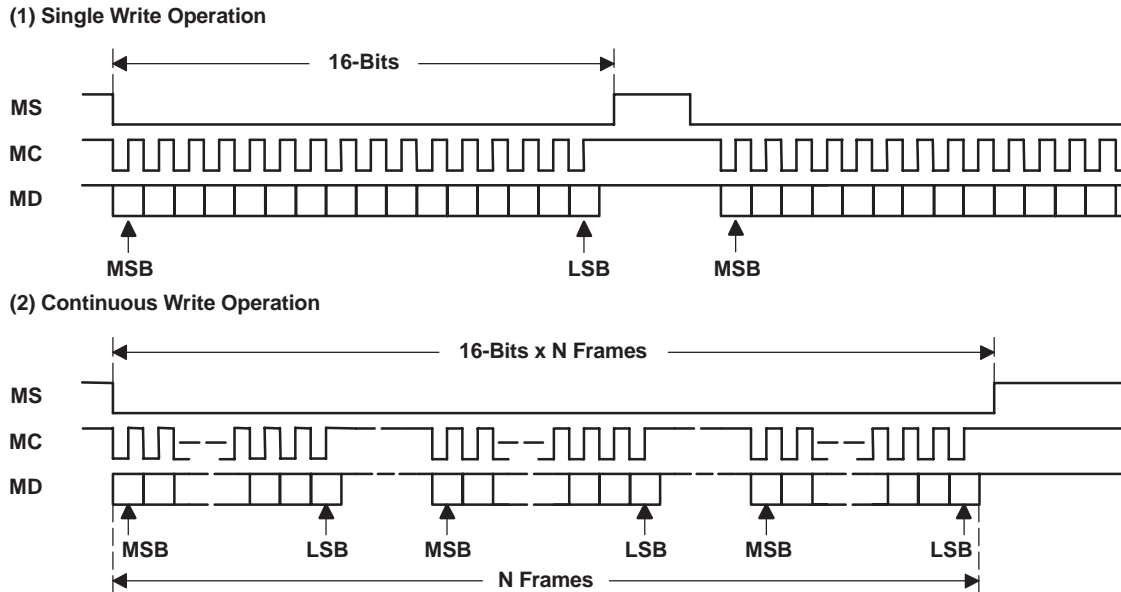

Figure 27. SPI Write Operation

## SPI REGISTER (PCM2705/7)

B15	B14	B13	B12	B11	B10	B9	B8	B7	B6	B5	B4	B3	B2	B1	B0
0	0	0	0	ST	0	ADDR	0	D0	D1	D2	D3	D4	D5	D6	D7

**D[7:0]** Function of the lower 8 bits depends on the value of the ST (B11) bit.

ST = 0 (HID status write)

- D7 Reports MUTE HID status to the host (active high)
- D6 Reports volume-up HID status to the host (active high)
- D5 Reports volume-down HID status to the host (active high)
- D4 Reports next-track HID status to the host (active high)
- D3 Reports previous-track HID status to the host (active high)
- D2 Reports stop HID status to the host (active high)
- D1 Reports play/pause HID status to the host (active high)
- D0 Reports extended command status to the host (active high)

ST = 1 (ROM data write)

D[7:0] Internal descriptor ROM data

**ADDR** Starts write operation for internal descriptor reprogramming (active high)

456 bits of ROM data, (described in the *External ROM Example* section) must be provided when this bit is asserted.

To set ADDR high, ST must be set low. Note that the lower 8 bits are still active when ST is set low.

**ST** Determines the function of the lower 8-bit data as follows

- 0: HID status write
- 1: Descriptor ROM data write



### Functionality of ST and ADDR Bit Combinations

ST	ADDR	FUNCTION
0	0	HID status write
0	1	HID status write and descriptor ROM address read
1	0	Descriptor ROM data write
1	1	Reserved

### USB HOST INTERFACE SEQUENCE

#### Power-On, Attach, and Playback Sequence

The PCM2704/5/6/7 is ready for setup when the reset sequence has finished and the USB bus is attached. After a connection has been established by setup, the PCM2704/5/6/7 is ready to accept USB audio data. While waiting for the audio data (idle state), the analog output is set to bipolar zero (BPZ).

When receiving the audio data, the PCM2704/5/6/7 stores the first audio packet, which contains 1 ms of audio data, into the internal storage buffer. The PCM2704/5/6/7 starts playing the audio data after detecting the next subsequent start-of-frame (SOF) packet.

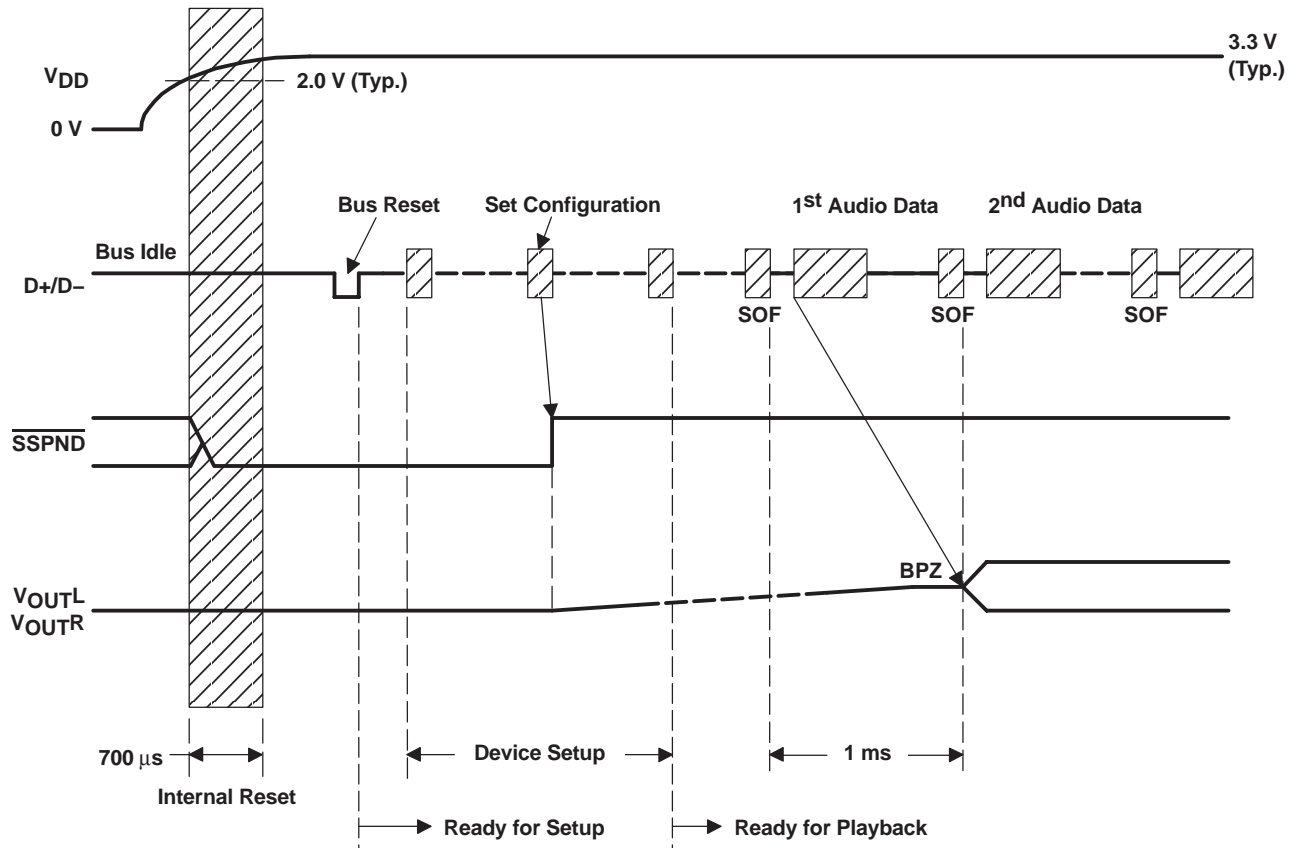

Figure 28. Initial Sequence

### Play, Stop, and Detach Sequence

When host finishes or aborts the playback, the PCM2704/5/6/7 stops the playing after last audio data has played.

### Suspend and Resume Sequence

The PCM2704/5/6/7 enters the suspend state after the USB bus has been in a constant idle state for approximately 5 ms. While the PCM2704/5/6/7 is in the suspend state, SSPND flag (pin 27 for PCM2704/5, pin 11 for PCM2706/7) is asserted. The PCM2704/5/6/7 wakes up immediately when detecting the non-idle state on the USB bus.

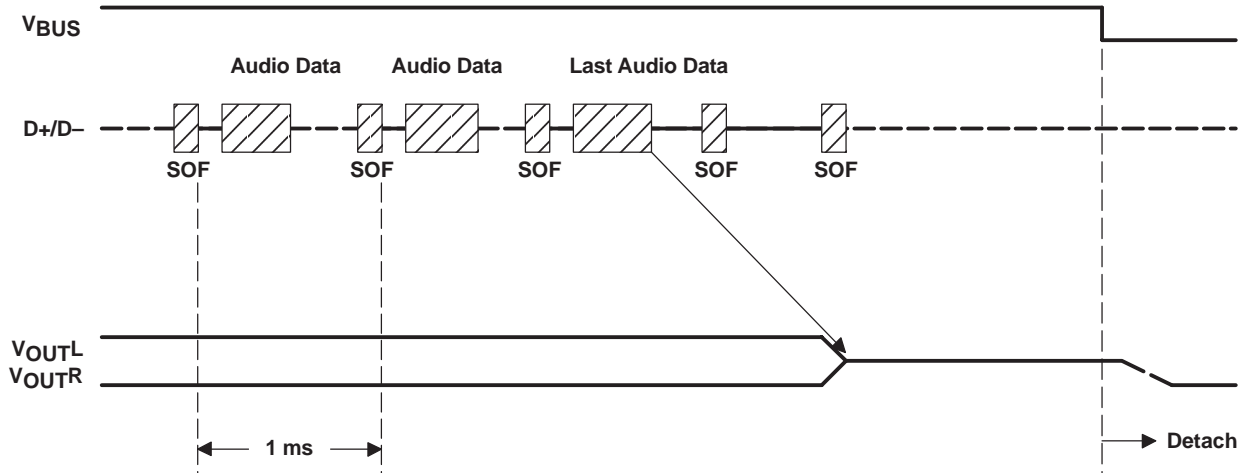

Figure 29. Play, Stop, and Detach

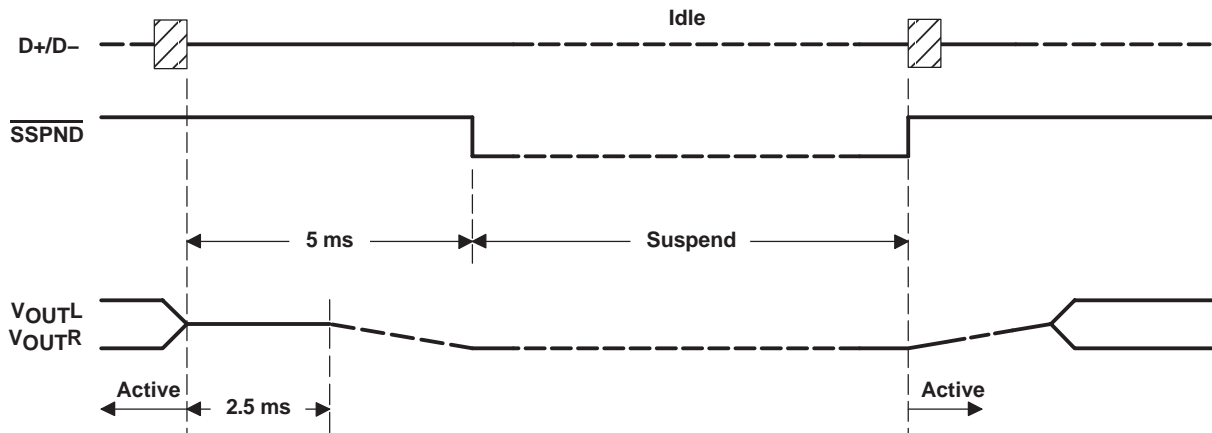
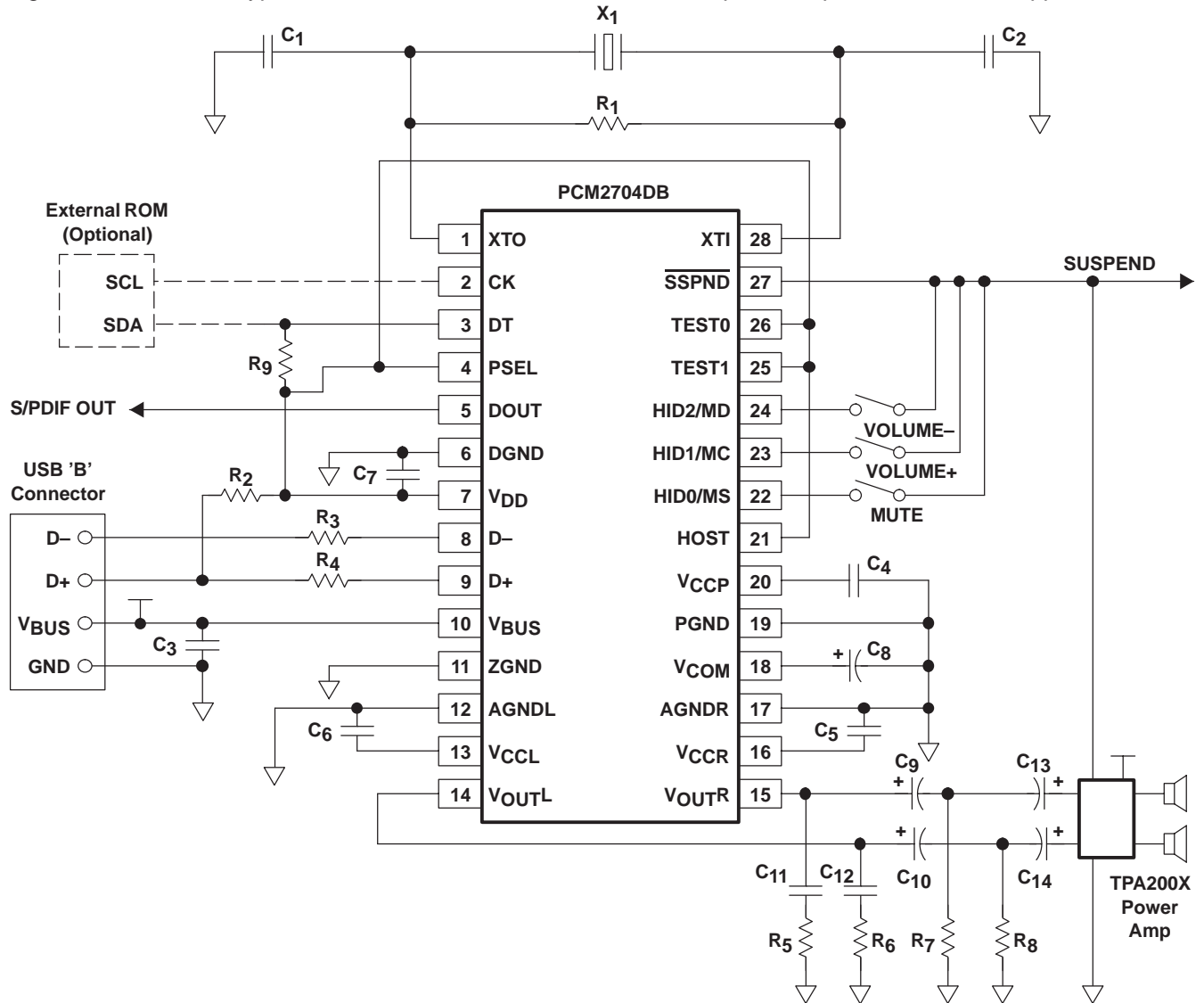

Figure 30. Suspend and Resume

## TYPICAL CIRCUIT CONNECTION 1 (EXAMPLE OF USB SPEAKER)

Figure 31 illustrates a typical circuit connection for an internal-descriptor, bus-powered, 500-mA application.



### Notes:

- X1: 12-MHz crystal resonator
  - C1, C2: 10-pF to 33-pF (depending on load capacitance of crystal resonator)
  - C3, C4, C5, C6, C7: 1- $\mu$ F ceramic
  - C8: 47- $\mu$ F electrolytic
  - C9, C10: 100- $\mu$ F electrolytic (depending on tradeoff between required frequency response and discharge time for resume)
  - C11, C12: 0.022- $\mu$ F ceramic
  - C13, C14: 1- $\mu$ F electrolytic
  - R1: 1 M $\Omega$
  - R2, R9: 1.5 k $\Omega$
  - R3, R4: 22  $\Omega$
  - R5, R6: 16  $\Omega$
  - R7, R8: 330  $\Omega$  (depending on tradeoff between required THD performance and pop-noise level for suspend)
- Output impedance of V<sub>OUTL</sub> and V<sub>OUTR</sub> during suspend mode or lack of power supply is 26 k $\Omega$   $\pm$ 20%, which is the discharge path for C<sub>9</sub> and C<sub>10</sub>. External ROM power can be supplied from V<sub>CCP</sub>, but any other active component must not use V<sub>CCP</sub>, V<sub>CCCL</sub>, V<sub>CCR</sub>, or V<sub>DD</sub> as a power source.

Figure 31. Bus-Powered Application

Note that the circuit illustrated above is for information only. Whole-board design should be considered to meet the USB specification as a USB-compliant product.

TYPICAL CIRCUIT CONNECTION 2 (EXAMPLE OF REMOTE HEADPHONE)

Figure 32 illustrates a typical circuit connection for a bus-powered, 100-mA headphone with seven HIDs.

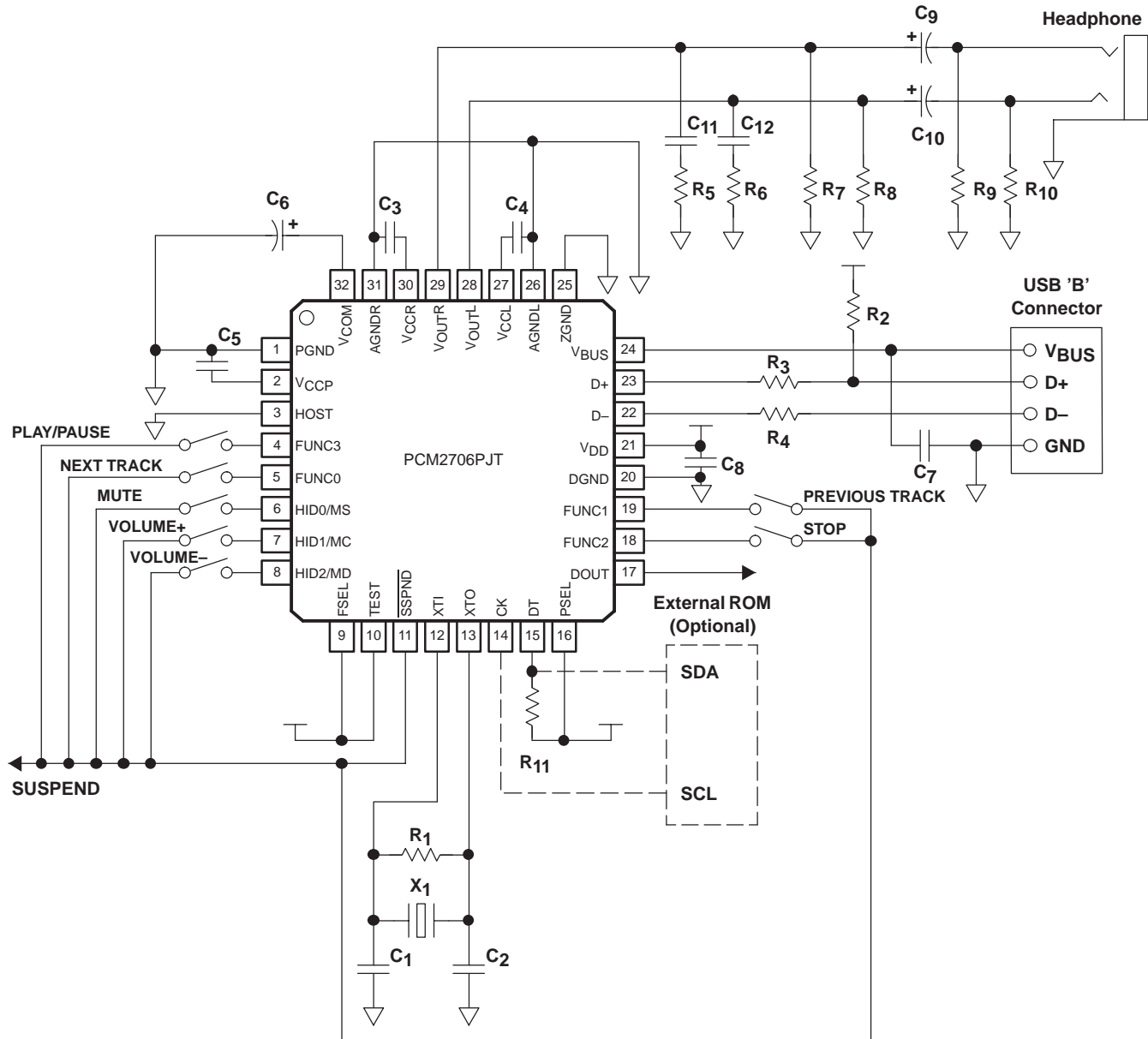

Notes:

- X<sub>1</sub>: 12-MHz crystal resonator
- C<sub>1</sub>, C<sub>2</sub>: 10-pF to 33-pF (depending on load capacitance of crystal resonator)
- C<sub>3</sub>, C<sub>4</sub>, C<sub>5</sub>, C<sub>7</sub>, C<sub>8</sub>: 1-μF ceramic
- C<sub>6</sub>: 47-μF electrolytic
- C<sub>9</sub>, C<sub>10</sub>: 100-μF electrolytic (depending on required frequency response)

C<sub>11</sub>, C<sub>12</sub>: 0.022-μF ceramic

- R<sub>1</sub>: 1 MΩ
- R<sub>2</sub>, R<sub>11</sub>: 1.5 kΩ
- R<sub>3</sub>, R<sub>4</sub>: 22 Ω
- R<sub>5</sub>, R<sub>6</sub>: 16 Ω
- R<sub>7</sub>, R<sub>8</sub>, R<sub>9</sub>, R<sub>10</sub>: 3.3 kΩ

External ROM power can be supplied from V<sub>CCP</sub>, but any other active component must not use V<sub>CCP</sub>, V<sub>CCL</sub>, V<sub>CCR</sub>, or V<sub>DD</sub> as a power source.

Figure 32. Bus-Powered Application

Note that the circuit illustrated above is for information only. Whole board design should be considered to meet the USB specification as a USB-compliant product.

### TYPICAL CIRCUIT CONNECTION 3 (EXAMPLE OF DSP SURROUND PROCESSING AMP)

Figure 33 illustrates a typical circuit connection for an I<sup>2</sup>S- and SPI-enabled self-powered application.

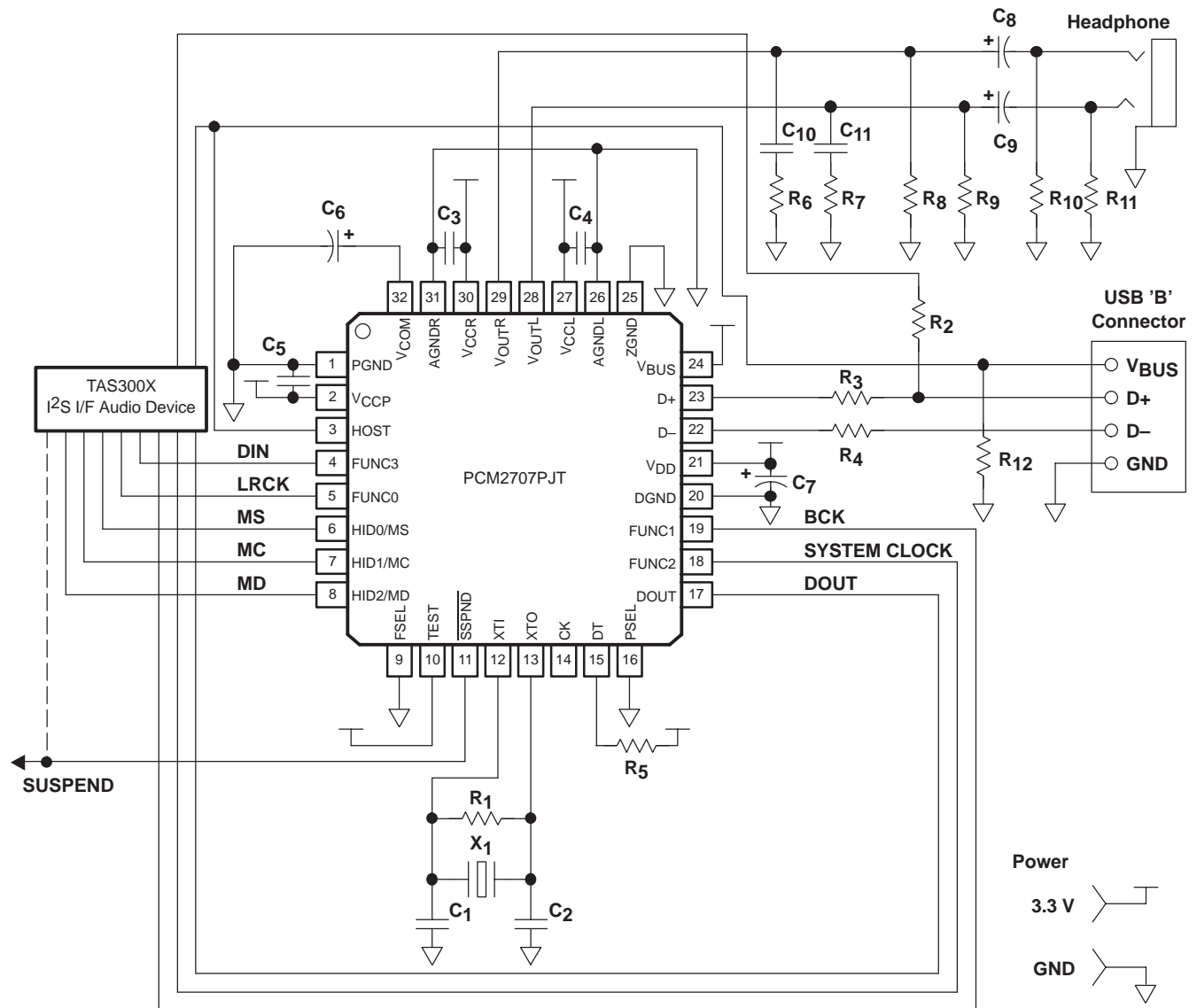

**Notes:**

- X<sub>1</sub>: 12-MHz crystal resonator
- C<sub>1</sub>, C<sub>2</sub>: 10-pF to 33-pF (depending on load capacitance of crystal resonator)
- C<sub>3</sub>, C<sub>4</sub>: 1-μF ceramic
- C<sub>5</sub>: 0.1-μF ceramic and 10-μF electrolytic
- C<sub>6</sub>, C<sub>7</sub>: 47-μF electrolytic

- C<sub>8</sub>, C<sub>9</sub>: 100-μF electrolytic (depending on required frequency response)
- C<sub>10</sub>, C<sub>11</sub>: 0.022-μF ceramic
- R<sub>1</sub>, R<sub>12</sub>: 1 MΩ
- R<sub>2</sub>, R<sub>5</sub>: 1.5 kΩ
- R<sub>3</sub>, R<sub>4</sub>: 22 Ω
- R<sub>6</sub>, R<sub>7</sub>: 16 Ω
- R<sub>8</sub>, R<sub>9</sub>, R<sub>10</sub>, R<sub>11</sub>: 3.3 kΩ

SPI host (DSP) must have responsibility to handle D+ pullup if descriptor is programmed by SPI. SPI host must not activate D+ pullup until all internal registers have been set. D+ must not activate (HIGH: 3.3 V) before programming of the PCM2707 by SPI is completed. D+ must not activate (HIGH: 3.3 V) while the device is detached from the USB. V<sub>BUS</sub> of the USB can be used to detect USB bus power status. (Note that V<sub>BUS</sub> of the USB connector is 5 V.)

**Figure 33. Self-Powered Application**

**Note that the circuit illustrated above is for information only. Whole board design should be considered to meet the USB specification as a USB-compliant product.**

## APPENDIX

### OPERATING ENVIRONMENT

For appropriate operation, one of the following operating systems must be running on a host PC equipped with a USB port certified by the manufacturer. If these conditions are met, the operation of the PCM2704/5/6/7 does not depend on the operating speed of the CPU. Texas Instruments has tested and confirmed the following listed operating environments. The PCM2704/5/6/7 may work with other PCs and operating systems also, but proper operation using them has not been tested and cannot be assured by TI.

#### Operating System

- Microsoft™ Windows™ 98SE/Windows Me™ Japanese/English edition (For Windows 98SE and Windows Me, the HID function is not fully functional with the default class driver.)
- Microsoft Windows 2000 Professional Japanese/English edition
- Microsoft Windows XP™ Home/Professional Japanese/English edition (For Windows XP, use the latest version of the USB audio driver, which is available on the Windows update site, or apply Service Pack 1. See the Q310507 white paper available from Microsoft.)
- Apple Computer Mac OS™ 9.1 or later Japanese/English edition
- Apple Computer Mac OS X 10.0 or later English edition
- Apple Computer Mac OS X 10.1 or later Japanese edition SP (For the Mac OS X 10.0 Japanese edition, plug and play does not work appropriately for USB audio devices.)

#### PC: One of These PC-AT Compatible Computers Running a Listed OS (OS Requirement Must Be Met)

- Motherboard using Intel 440 BX or ZX chipset (using the USB controller in the chipset)
- Motherboard using Intel i810 chipset (using the USB controller in the chipset)
- Motherboard using Intel i815 chipset (using the USB controller in the chipset)
- Motherboard using Intel i820 chipset (using the USB controller in the chipset)
- Motherboard using Intel i845 chipset (using the ICH2 USB controller in the chipset)
- Motherboard using Intel i845 chipset (using the ICH4 USB controller in the chipset)
- Motherboard using Intel i850 chipset (using the USB controller in the chipset)
- Motherboard using Intel i848 chipset (using the ICH5/R USB controller in the chipset)
- Motherboard using Intel i865 chipset (using the ICH5/R USB controller in the chipset)
- Motherboard using Intel i875 chipset (using the ICH5/R USB controller in the chipset)
- Motherboard using Apollo™ KT133 chipset (using the USB controller in the chipset)
- Motherboard using Apollo KT333 chipset (using the USB controller in the chipset)
- Motherboard using Apollo Pro plus chipset (using the USB controller in the chipset)
- Motherboard using MVP4 or MVP3 chipset (using the USB controller in the chipset)
- Motherboard using Aladdin V chipset (using the USB controller in the chipset)
- Motherboard using SiS530 or SiS559 chipset (using the USB controller in the chipset)
- Motherboard using SiS735 chipset (using the USB controller in the chipset)

NOTE: The PCM2704/5/6/7 has been acknowledged in a USB compliance test. However, the acknowledgement is for the PCM2704/5/6/7 device only, and does not apply to the customer's system using the PCM2704/5/6/7.

Intel is a trademark of Intel Corporation.

Mac OS is a trademark of Apple Computer, Inc.

Microsoft, Windows, Windows Me, and Windows XP are trademarks of Microsoft Corporation.

Other trademarks are the property of their respective owners.



DB (R-PDSO-G\*\*)

PLASTIC SMALL-OUTLINE

28 PINS SHOWN



- NOTES: A. All linear dimensions are in millimeters.  
 B. This drawing is subject to change without notice.  
 C. Body dimensions do not include mold flash or protrusion not to exceed 0,15.  
 D. Falls within JEDEC MO-150



## IMPORTANT NOTICE

Texas Instruments Incorporated and its subsidiaries (TI) reserve the right to make corrections, modifications, enhancements, improvements, and other changes to its products and services at any time and to discontinue any product or service without notice. Customers should obtain the latest relevant information before placing orders and should verify that such information is current and complete. All products are sold subject to TI's terms and conditions of sale supplied at the time of order acknowledgment.

TI warrants performance of its hardware products to the specifications applicable at the time of sale in accordance with TI's standard warranty. Testing and other quality control techniques are used to the extent TI deems necessary to support this warranty. Except where mandated by government requirements, testing of all parameters of each product is not necessarily performed.

TI assumes no liability for applications assistance or customer product design. Customers are responsible for their products and applications using TI components. To minimize the risks associated with customer products and applications, customers should provide adequate design and operating safeguards.

TI does not warrant or represent that any license, either express or implied, is granted under any TI patent right, copyright, mask work right, or other TI intellectual property right relating to any combination, machine, or process in which TI products or services are used. Information published by TI regarding third-party products or services does not constitute a license from TI to use such products or services or a warranty or endorsement thereof. Use of such information may require a license from a third party under the patents or other intellectual property of the third party, or a license from TI under the patents or other intellectual property of TI.

Reproduction of information in TI data books or data sheets is permissible only if reproduction is without alteration and is accompanied by all associated warranties, conditions, limitations, and notices. Reproduction of this information with alteration is an unfair and deceptive business practice. TI is not responsible or liable for such altered documentation.

Resale of TI products or services with statements different from or beyond the parameters stated by TI for that product or service voids all express and any implied warranties for the associated TI product or service and is an unfair and deceptive business practice. TI is not responsible or liable for any such statements.

Following are URLs where you can obtain information on other Texas Instruments products and application solutions:

<b>Products</b>		<b>Applications</b>	
Amplifiers	<a href="http://amplifier.ti.com">amplifier.ti.com</a>	Audio	<a href="http://www.ti.com/audio">www.ti.com/audio</a>
Data Converters	<a href="http://dataconverter.ti.com">dataconverter.ti.com</a>	Automotive	<a href="http://www.ti.com/automotive">www.ti.com/automotive</a>
DSP	<a href="http://dsp.ti.com">dsp.ti.com</a>	Broadband	<a href="http://www.ti.com/broadband">www.ti.com/broadband</a>
Interface	<a href="http://interface.ti.com">interface.ti.com</a>	Digital Control	<a href="http://www.ti.com/digitalcontrol">www.ti.com/digitalcontrol</a>
Logic	<a href="http://logic.ti.com">logic.ti.com</a>	Military	<a href="http://www.ti.com/military">www.ti.com/military</a>
Power Mgmt	<a href="http://power.ti.com">power.ti.com</a>	Optical Networking	<a href="http://www.ti.com/opticalnetwork">www.ti.com/opticalnetwork</a>
Microcontrollers	<a href="http://microcontroller.ti.com">microcontroller.ti.com</a>	Security	<a href="http://www.ti.com/security">www.ti.com/security</a>
		Telephony	<a href="http://www.ti.com/telephony">www.ti.com/telephony</a>
		Video & Imaging	<a href="http://www.ti.com/video">www.ti.com/video</a>
		Wireless	<a href="http://www.ti.com/wireless">www.ti.com/wireless</a>

Mailing Address: Texas Instruments  
Post Office Box 655303 Dallas, Texas 75265